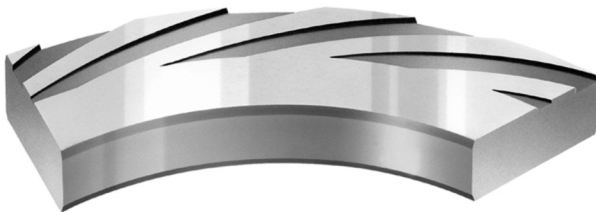
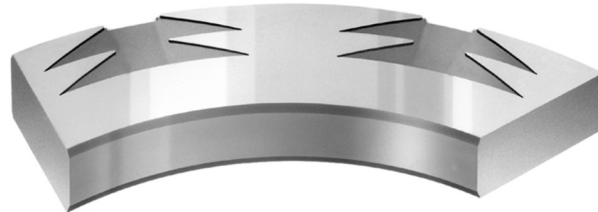
**Standard Unidirectional Groove Design****Optional Bidirectional Groove Design**

Product Description

Type 28 compressor dry-running gas seals have been the industry standard since the 1970s for gas-handling turbomachinery. Utilizing John Crane's patented spiral groove pattern, these seals are non-contacting in operation.

- During dynamic operation, the mating ring/seat and primary ring/face maintain a sealing gap of approximately 0.0002 in./5 microns, thereby eliminating wear
- These seals eliminate seal oil contamination and reduce maintenance costs and downtime
- Single, double opposed, and tandem cartridge seals are capable of handling a wide variety of gas sealing applications in the gas collection/transmission, refining, chemical and petrochemical processing industries

Design Features

- Shrouded mating ring prevents secondary damage in the event of a mating ring fracture
- Low-level leakage can be vented to a safe area, used as fuel to drive equipment, or returned to process via a low-pressure ejector

Performance Capabilities

- Temperature: -220°F to 600°F/-140°C to 315°C
- Pressure: Up to 6,500 psi(g)/450 bar(g) across single stage
- Speed: Up to 660 fps/200 m/s
- Shaft: Up to 13.75"/350mm

TYPE 28

DRY-RUNNING, NON-CONTACTING GAS SEALS

Type 28AT Tandem Arrangement

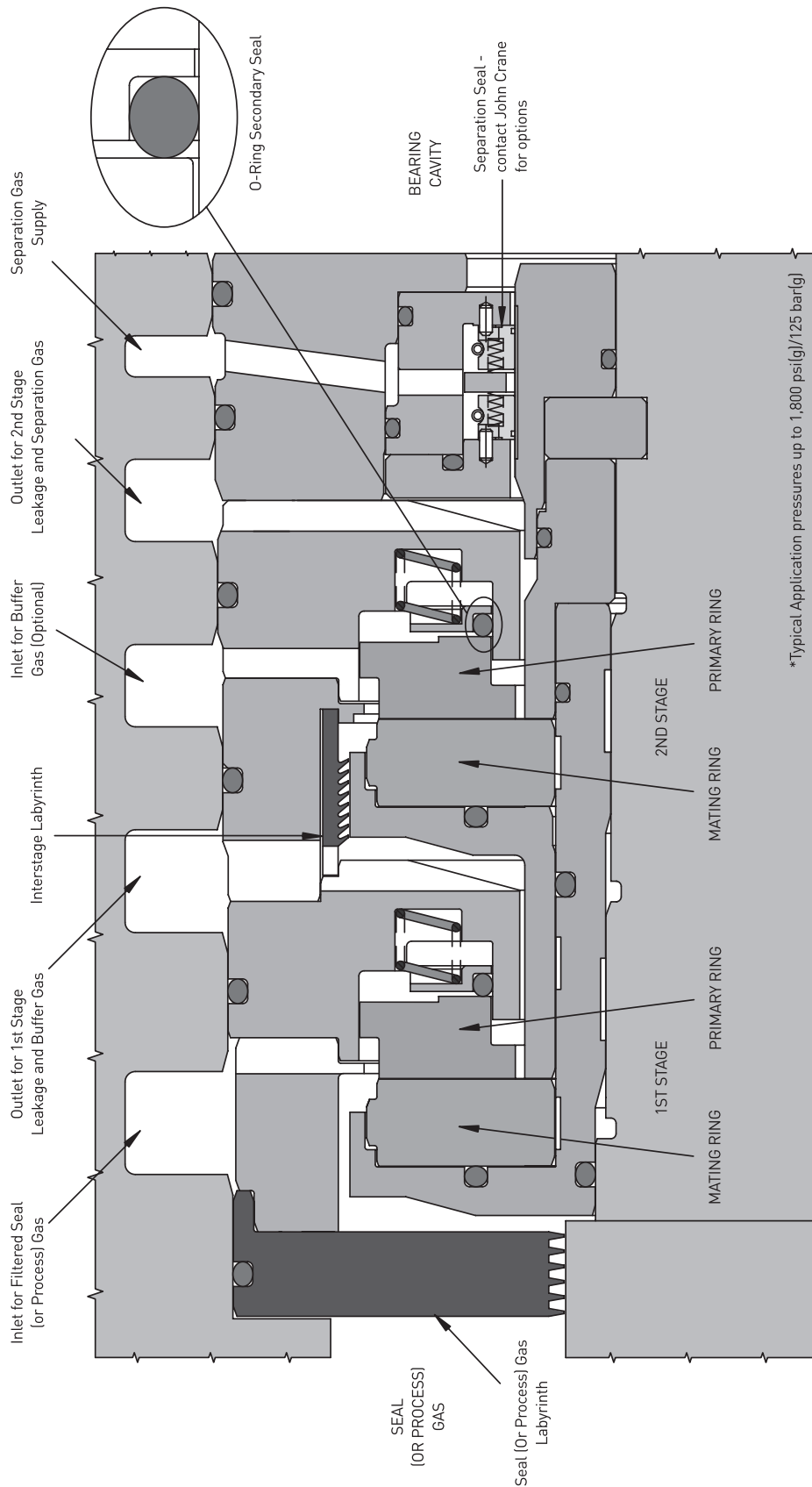

TYPE 28

DRY-RUNNING, NON-CONTACTING GAS SEALS

Type 28XP Tandem Arrangement

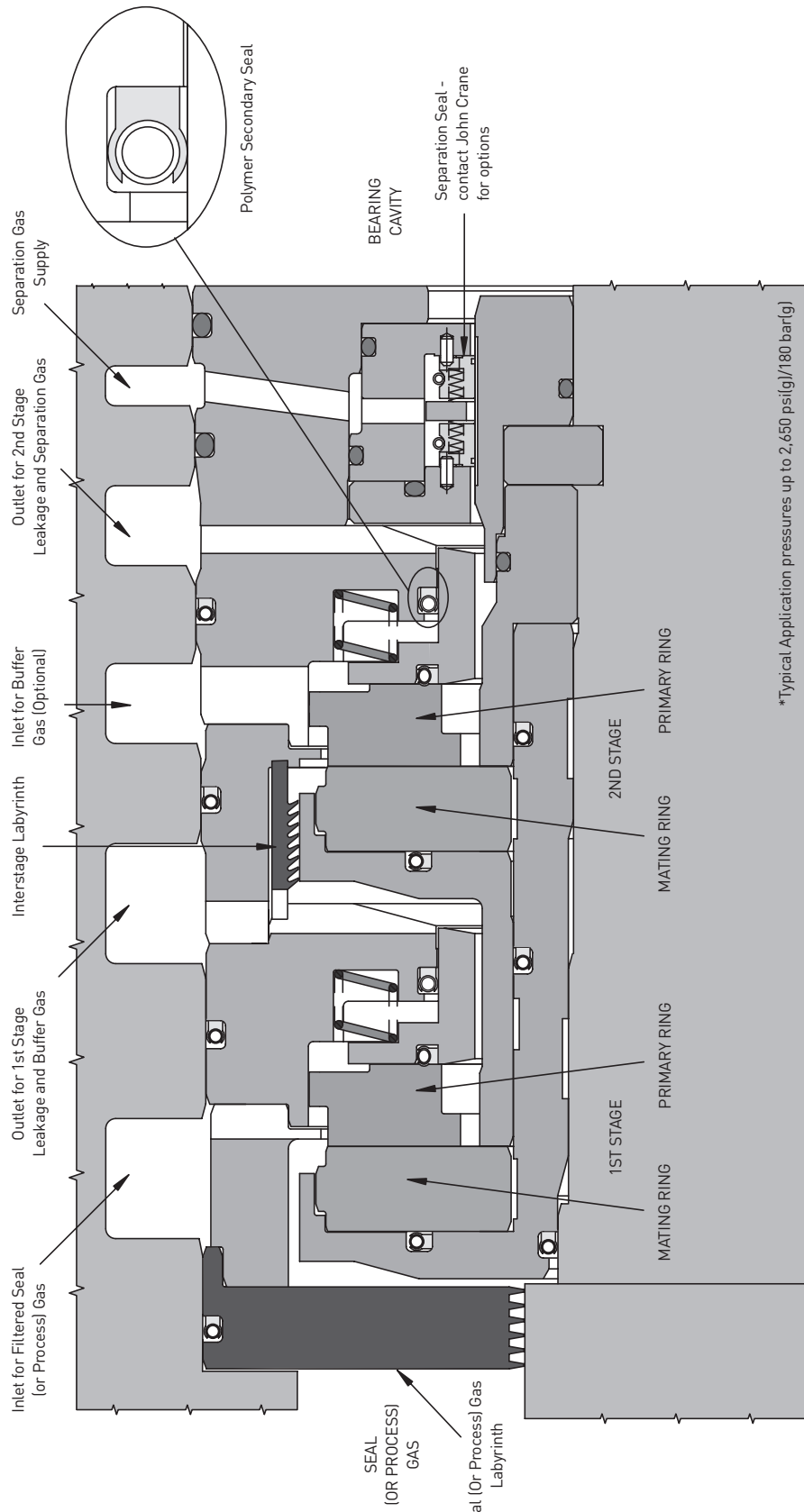

TYPE 28

DRY-RUNNING, NON-CONTACTING GAS SEALS

Type 28XP-S Tandem Arrangement

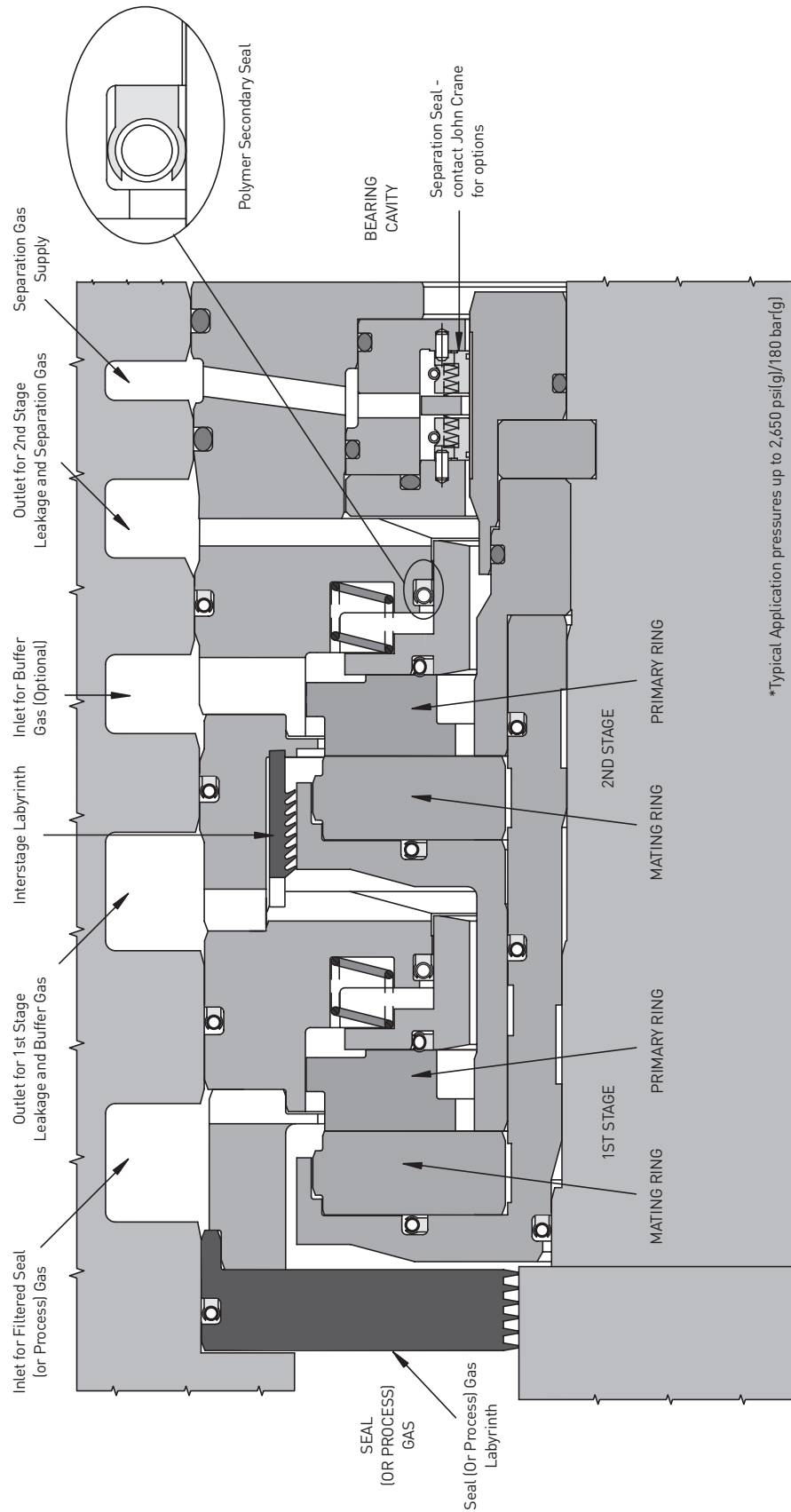

TYPE 28

DRY-RUNNING, NON-CONTACTING GAS SEALS

Type 28EXP Tandem Arrangement

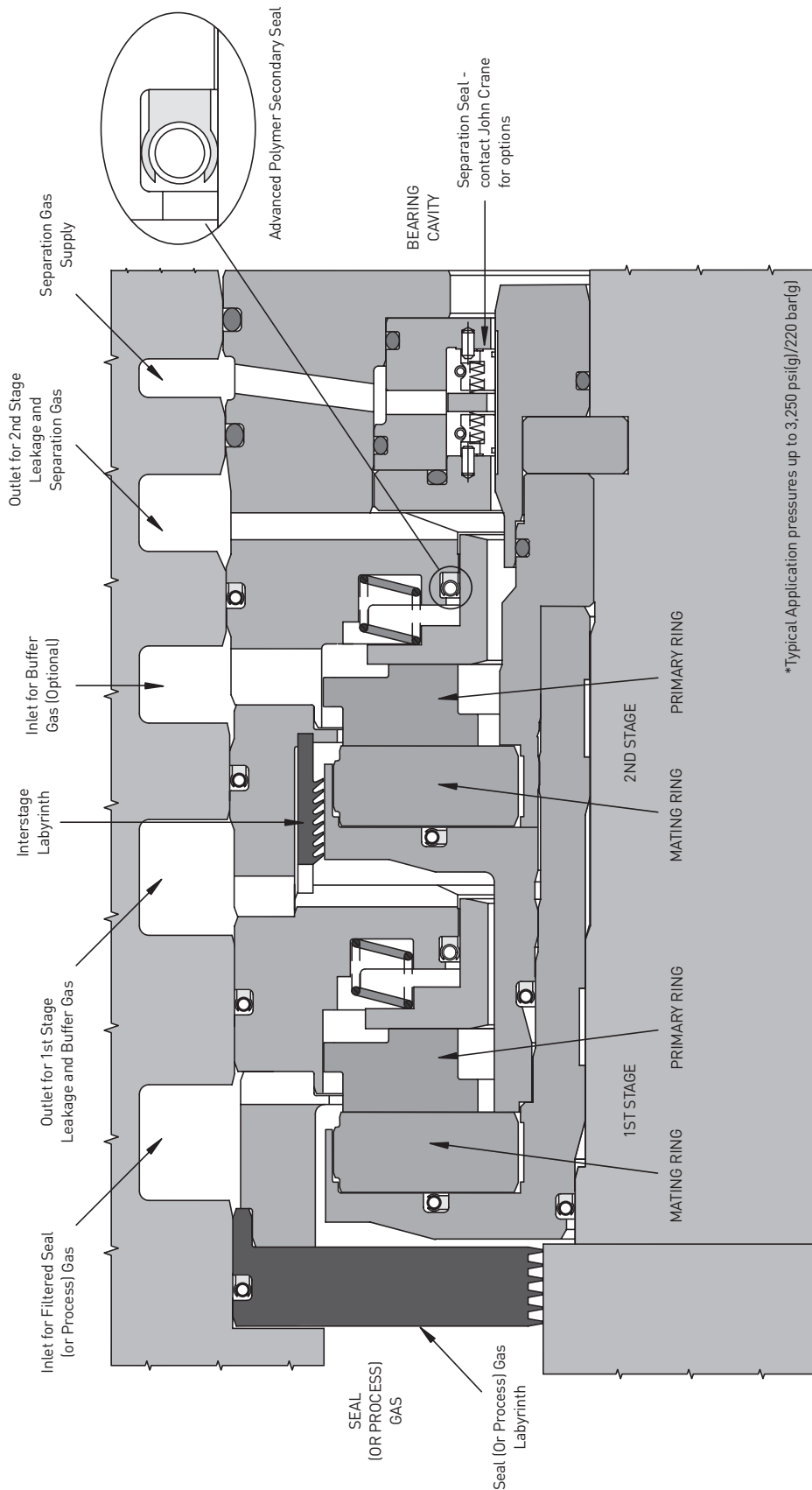

Typical Single Seal Arrangement and Seal Support System

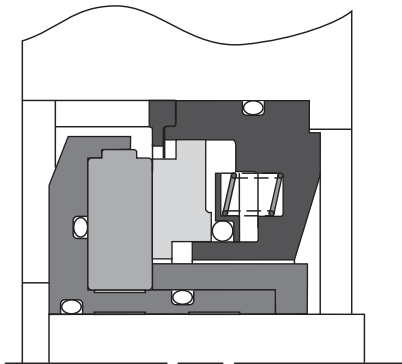

*Single Seal Arrangement for applications not requiring a safety back-up seal.

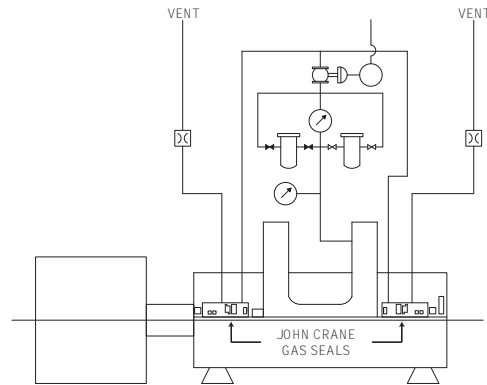

Typical Double Opposed Seal Arrangement and Seal Support System

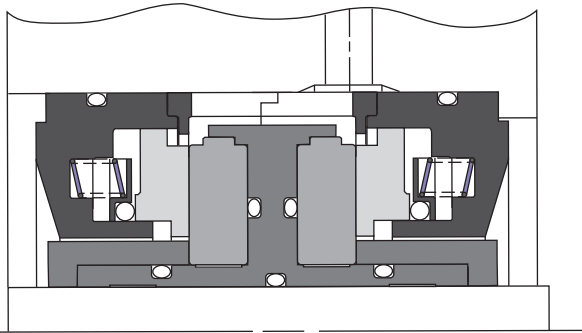

*Double Seal Arrangement where hazardous gas is not permissible to leak into atmosphere.

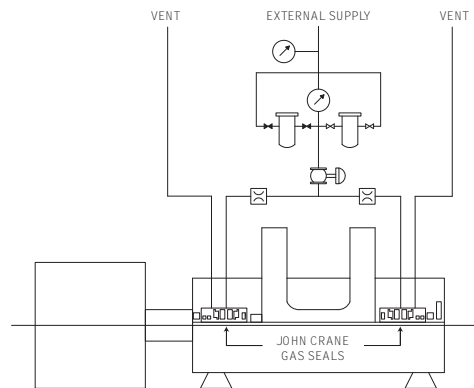

Typical Tandem Seal Arrangement and Seal Support System

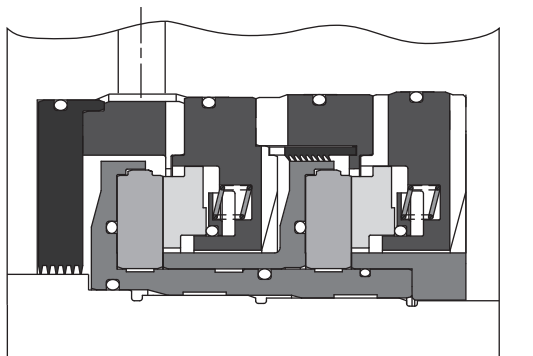

*Tandem Seal Arrangement for applications requiring a safety back-up seal.

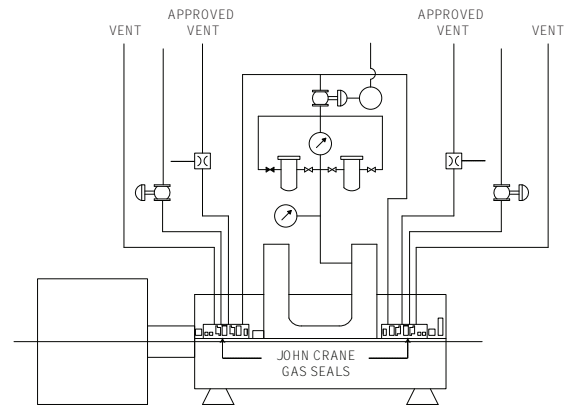

Size and Speed Effect on Leakage

Conditions: Air, 1,200 psig/83 bar g

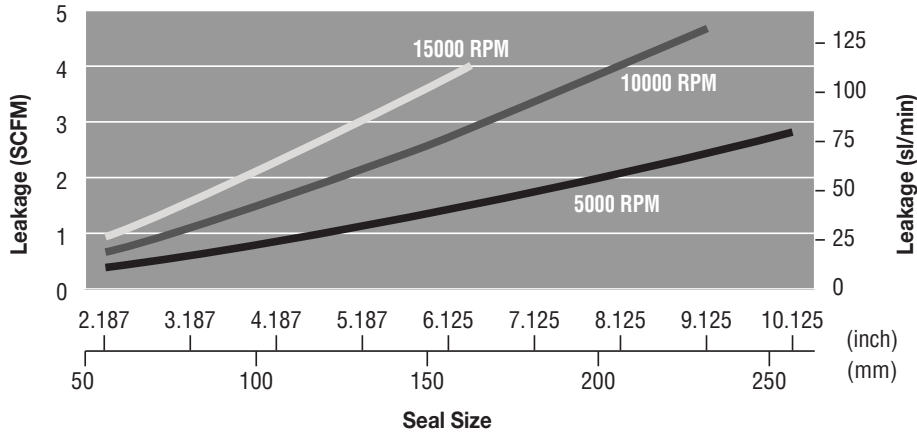

Pressure, Temperature and Gas Effect on Leakage

Conditions: 6.187-inch Diameter Seal, 14,000 rpm

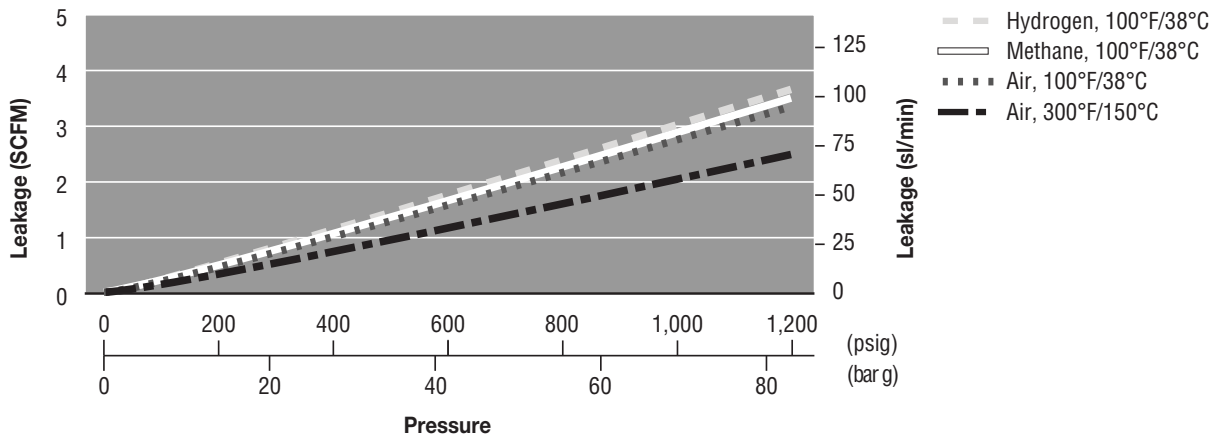

Gas Seal Power Consumption

Conditions: Air, 140°F/60°C

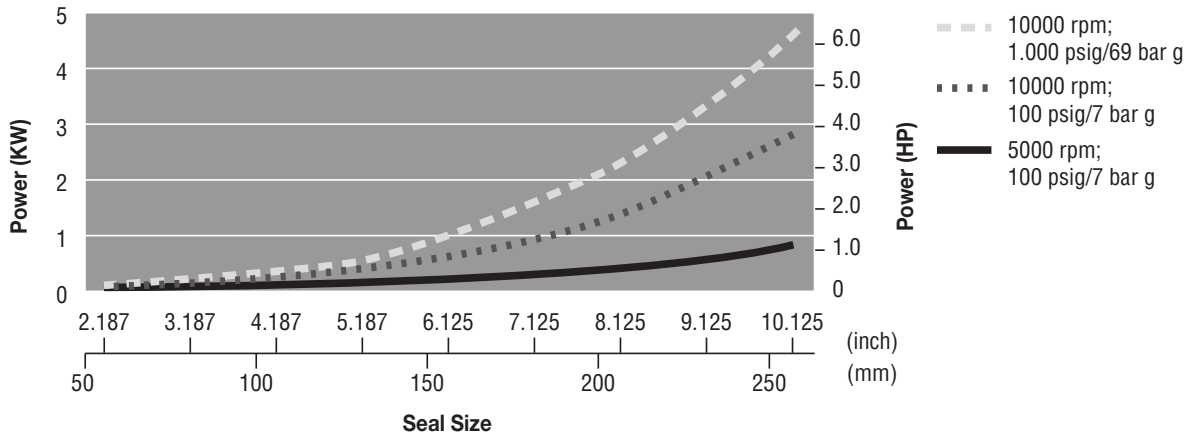

*This information should not be used for specification purposes. Contact DryGasSeals@johncrane.com for more information about exact application requirements.

