

- A** – Seat/Mating Ring
- B** – Face/Primary Ring
- C** – Split Carbon Ring Assemblies

Spiral Groove Face

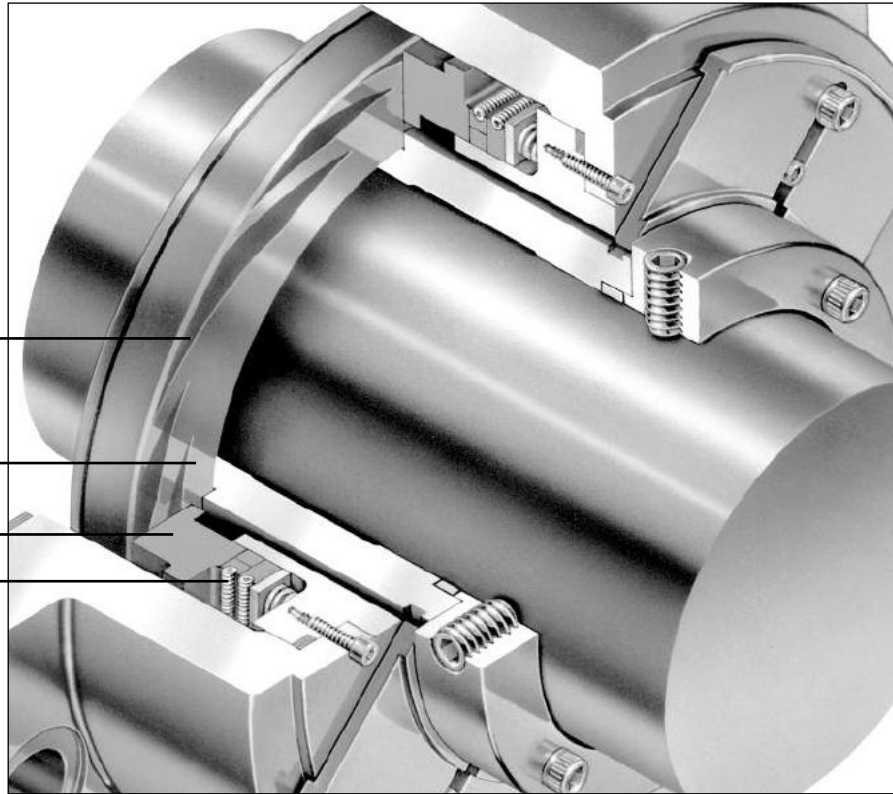

### Product Description

Type 28ST combines proven rotating groove technology and high-temperature secondary seals to reduce steam leakage by nearly two orders of magnitude, as compared to traditional sealing devices such as segmented carbon rings and labyrinths.

- This steam-lubricated, end-face cartridge seal reacts instantaneously and automatically to maintain a safe face gap despite sudden changes in operating conditions
- A stable seal face gap, typically 0.0025mm to 0.0051mm/ 0.0001" to 0.0002", is the result of specially designed rotating grooves, which pump steam radially inward into a nongrooved portion of the seal known as the "sealing dam"
- Primarily for use on steam turbines

### Design Features

- Bearing oil steam contamination dramatically reduced
- Increased safety (reduced noise levels and hazards associated with leaking steam)
- Standard designs to fit most single-stage turbines
- Turbine operational efficiency maintained for years
- Support equipment eliminated
- Bi-directional face patterns available

### Performance Capabilities

- Temperature: up to 400°C/750°F
- Pressure: up to 27.6 bar g/400 psig
- Speed: up to 122 m/s/400 fps max.
- End play/axial float allowance:  $\pm 3.20\text{mm}/0.125\text{"}$
- Optimum seal performance: steam should have 28°C to 56°C/83°F to 133°F of superheat at inlet conditions.
- Optimum seal life: following a combination of NEMA Standard SM 24-1991 and EPRI guidelines for steam purity is strongly recommended. Consult John Crane for recommended steam purity limits.

# TYPE 28ST

## NON-CONTACTING, STEAM TURBINE GAS SEAL

### Type 28ST Typical Arrangement

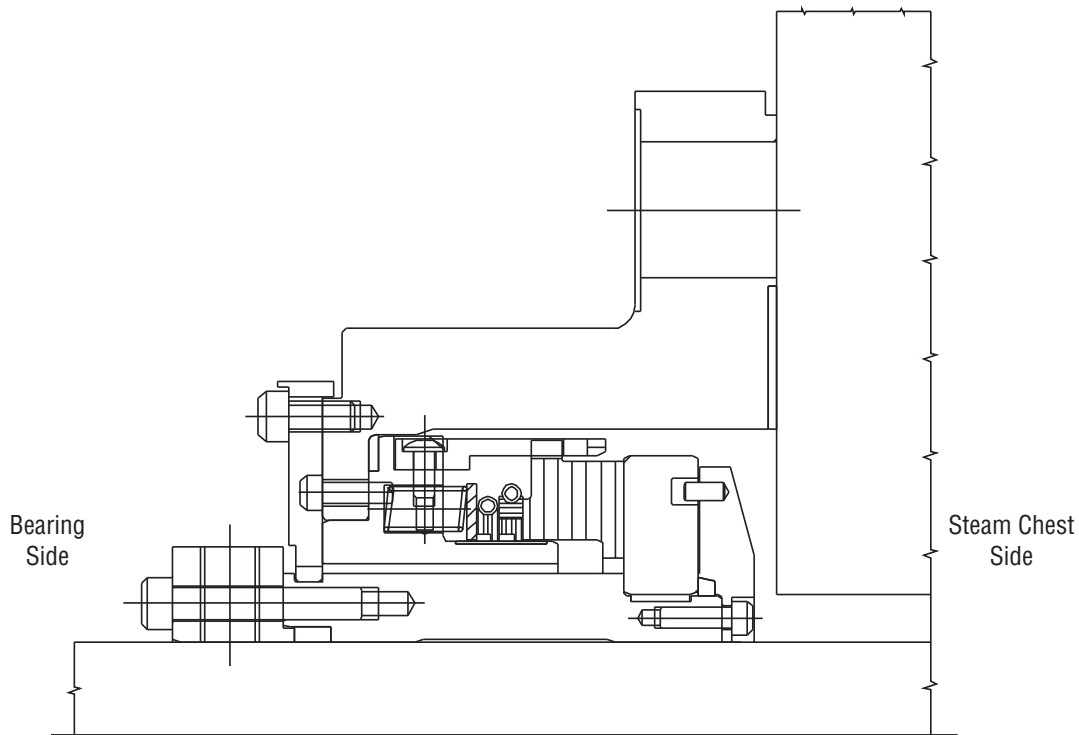

### Type 28ST Applications Data

The standard Type 28ST is designed to withstand speeds of 122 m/s/400 fps max. and 1000 rpm min. (continuous). It is also slow roll tolerable. The Type 28ST is designed to fit most single-stage turbines without modifications. Standard designs exist for shaft sizes ranging from 25.4mm/1.000" through 108mm/4.250" for most steam turbines, including: Coppus, Dean Hill, Dresser Rand (Terry, Worthington), Elliott, Hayward Tyler, KKK, Murray, Rateau,

Spencer Turbine, and Tuthill Nadrowski models. Larger, nonstandard sizes are available. Consult John Crane for your specific application.

The Type 28ST has an excellent track record in the most demanding steam turbine applications.

### Recommended Minimum Inlet Temperature vs. Inlet Pressure

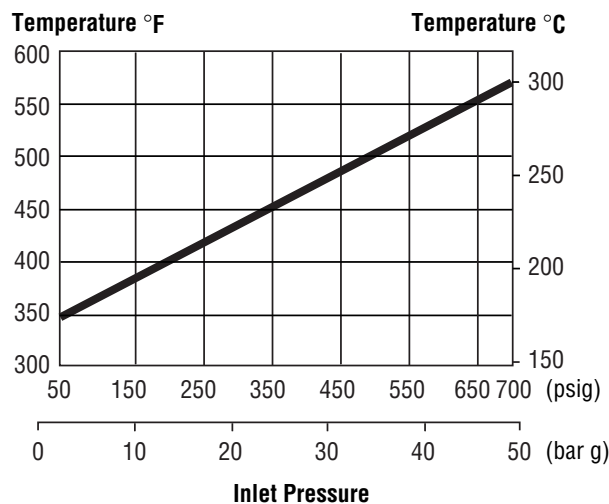

#### Obtaining Optimum Performance

Steam purity (cleanliness) and steam quality (percent vapor) are probably the two most critical ingredients in achieving optimum performance from your steam turbine and your Type 28ST seal. John Crane suggests following a combination of the National Electrical Manufacturers' Association (NEMA) and the Electric Power Research Institute (EPRI) guidelines for steam purity limits for improved reliability of not only the Type 28ST seals, but also the entire steam turbine.

Consult John Crane for recommended steam purity limits. See chart at left for recommended steam quality operating conditions.

# TYPE 28ST

## NON-CONTACTING, STEAM TURBINE GAS SEAL

### Type 28ST Typical Leakage Chart\*

Steam Leakage (lbs./hr.)

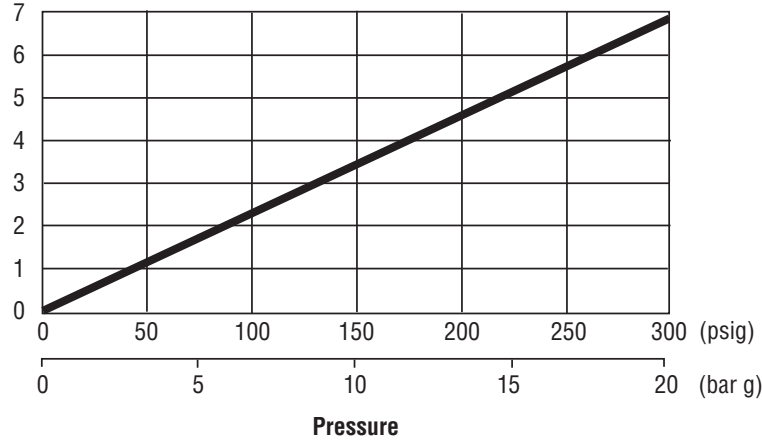

- Steam contamination of bearing oil virtually eliminated.
- Rust and corrosion of other equipment dramatically reduced.

### Conventional Segmented Carbon Rings Typical Leakage Chart\*

Steam Leakage (lbs./hr.)

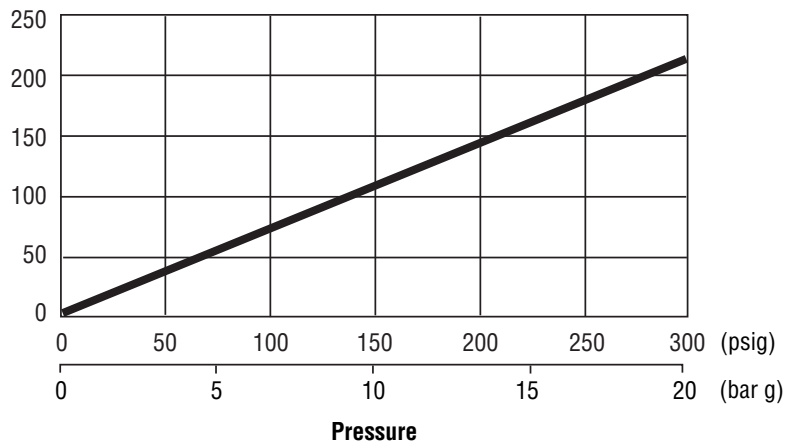

### Type 28ST Cost Savings vs. Traditional Seals\*

Steam Leakage (lbs./hr.)

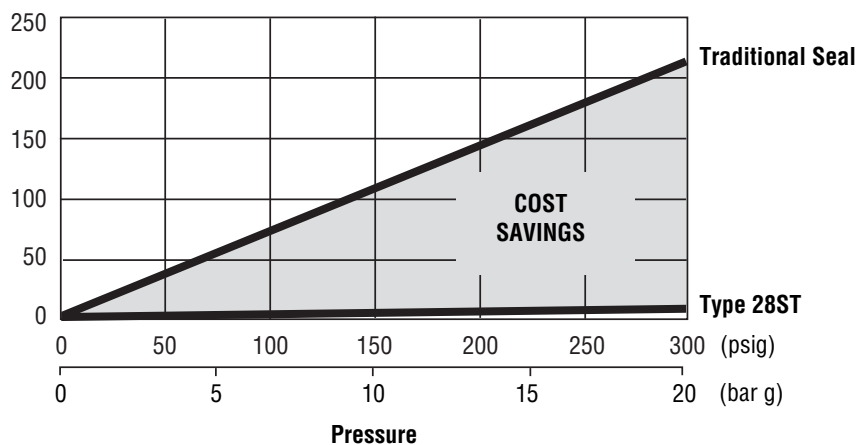

\*Based on an 88.9mm/3.500" shaft diameter.

### Materials of Construction

SEAL COMPONENTS	MATERIALS
Description	Standard
Face/Primary Ring	Carbon
Seat/Mating Ring	Tungsten Carbide Coatings on Ductile Substrates
Secondary Seals	Carbon/Inconel® Flexible Graphite
Hardware	410 Stainless Steel
Springs	Inconel® X-750
Fasteners	Zinc-Coated Hardened Steel

Inconel is a registered trademark of Inco Alloys International, Inc.