

# TYPE 1/1B

## ELASTOMER BELLOWS SEALS

- A - Face/Primary Ring
- B - Spring
- C - Elastomer Bellows
- D - Retainer
- E - Drive Band
- F - Spring Holder
- G - Disc

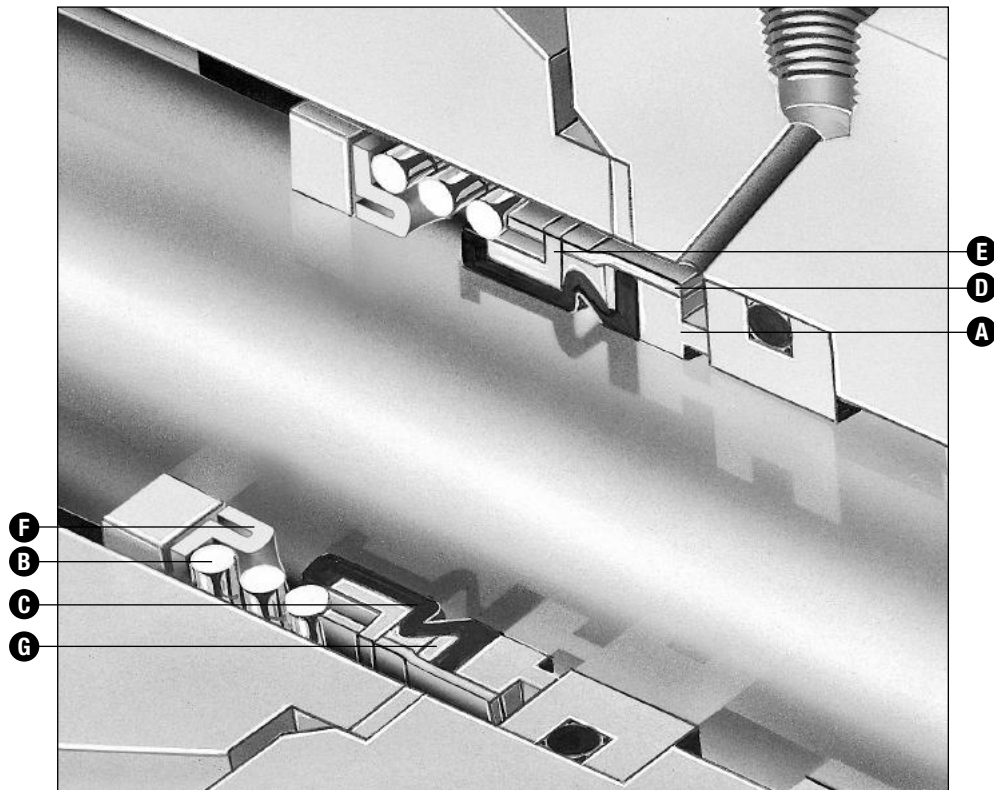

### Product Description

John Crane's Type 1 elastomer bellows seal is widely recognized as the industry workhorse with a proven track record of exceptional performance. The Type 1 is suitable for a wide range of service conditions from water and steam to chemicals and corrosive materials.

- For use in pumps, mixers, blenders, agitators, refrigeration compressors, blowers, fans and other rotary shaft equipment
- For pulp and paper, petrochemical, food processing, wastewater treatment, chemical processing, power generation and other demanding applications

### Design Features

- Mechanical drive — eliminates overstressing of bellows
- Self-aligning capability — automatic adjustment compensates for abnormal shaft end play runout, primary ring wear and equipment tolerances
- Special balancing — for higher pressure applications and less wear
- Non-clogging, single-coil spring — not affected by buildup of solids
- Low drive torque — improves performance and reliability

### Performance Capabilities

- Temperature: -40°C to 205°C/-40°F to 400°F (depending on materials used)
- Pressure: 1: up to 29 bar g/425 psig  
1B: up to 82 bar g/1200 psig
- Speed: See enclosed speed limits chart.

# TYPE 1/1B

## ELASTOMER BELLOWS SEALS

### Type 1 Typical Arrangement

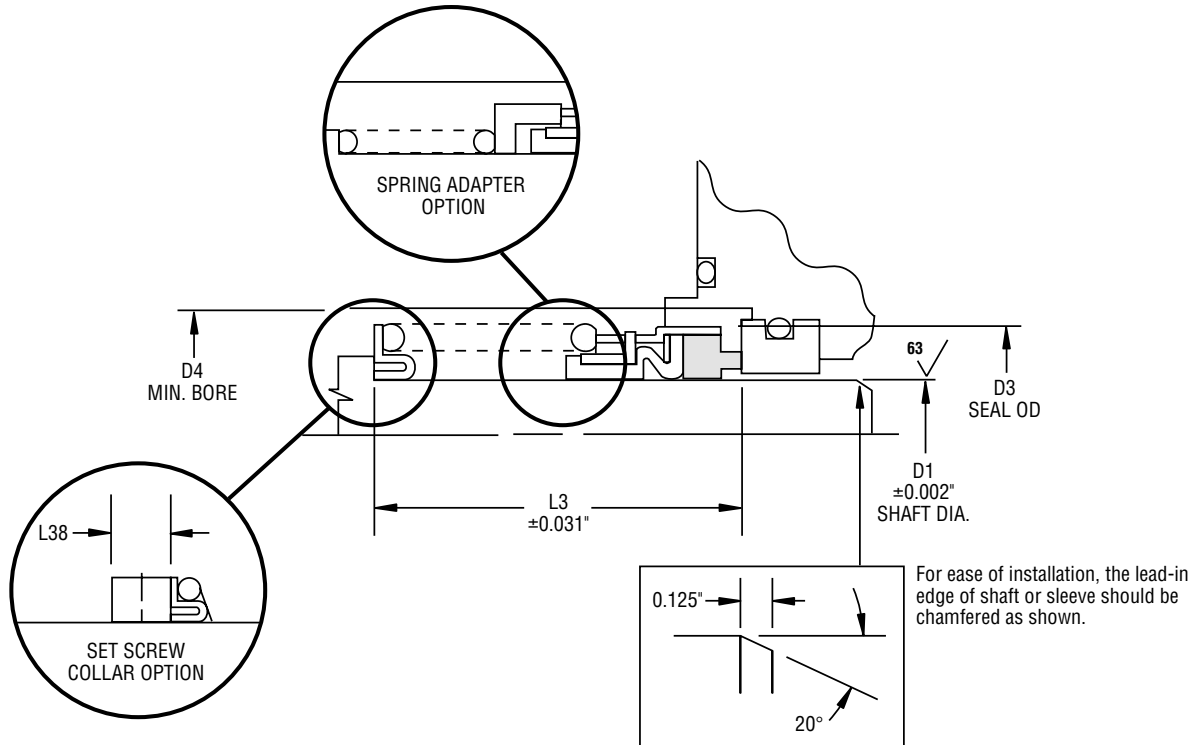

### Type 1 Dimensional Data (inches)

Seal Size/D1 (inches)	D3	D4	L3	L38
1.000	1.500	1.750	1.562	0.375
1.125	1.625	1.875	1.625	0.375
1.250	1.812	2.000	1.625	0.375
1.375	1.875	2.125	1.687	0.375
1.500	2.000	2.250	1.687	0.375
1.625	2.250	2.500	2.000	0.375
1.750	2.375	2.625	2.000	0.375
1.875	2.500	2.750	2.125	0.375
2.000	2.625	2.937	2.125	0.375
2.125	2.812	3.125	2.375	0.500
2.250	2.937	3.250	2.375	0.500
2.375	3.062	3.375	2.500	0.500
2.500	3.187	3.500	2.500	0.500
2.625	3.375	3.750	2.750	0.500
2.750	3.500	3.875	2.750	0.500
2.875	3.625	4.000	2.875	0.500
3.000	3.750	4.187	2.875	0.500
3.125	4.000	4.437	3.125	0.500
3.250	4.125	4.562	3.125	0.500
3.375	4.250	4.687	3.125	0.500
3.500	4.375	4.812	3.125	0.500
3.625	4.500	4.937	3.250	0.562
3.750	4.625	5.062	3.250	0.562
3.875	4.750	5.187	3.375	0.562
4.000	4.875	5.312	3.375	0.562

# TYPE 1/1B

## ELASTOMER BELLOWS SEALS

### Type 1B Typical Arrangement

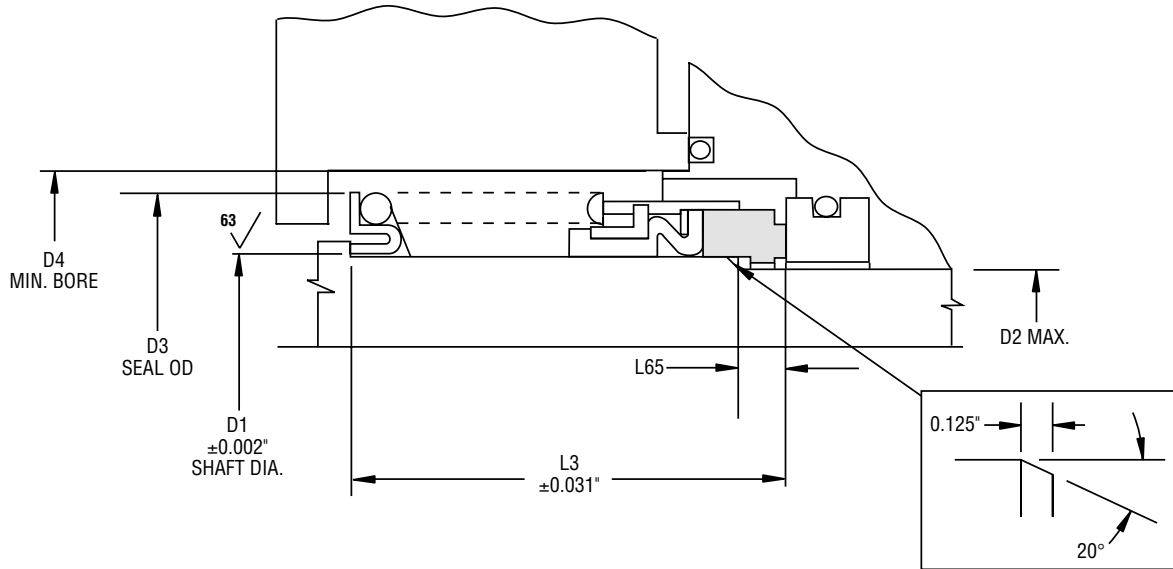

For ease of installation, the lead-in edge of shaft or sleeve should be chamfered as shown.

### Type 1B Dimensional Data (inches)

Seal Size/D1 (inches)	D2	D3	D4	L3	L65
1.000	0.875	1.500	1.750	1.875	0.343
1.125	1.000	1.625	1.875	1.937	0.343
1.250	1.125	1.812	2.062	1.937	0.343
1.375	1.250	1.875	2.125	2.000	0.343
1.500	1.375	2.000	2.250	2.000	0.343
1.625	1.500	2.250	2.500	2.375	0.437
1.750	1.625	2.375	2.625	2.375	0.437
1.875	1.750	2.500	2.750	2.500	0.437
2.000	1.875	2.625	2.937	2.500	0.437
2.125	2.000	2.812	3.125	2.750	0.500
2.250	2.125	2.937	3.250	2.750	0.500
2.375	2.250	3.062	3.375	2.875	0.500
2.500	2.375	3.187	3.500	2.875	0.500
2.625	2.500	3.375	3.750	3.125	0.562
2.750	2.625	3.500	3.875	3.125	0.562
2.875	2.750	3.625	4.000	3.250	0.562
3.000	2.875	3.750	4.187	3.250	0.562
3.125	2.875	4.000	4.437	3.500	0.625
3.250	3.000	4.125	4.562	3.500	0.625
3.375	3.125	4.250	4.687	3.500	0.625
3.500	3.250	4.375	4.812	3.500	0.625
3.625	3.375	4.500	4.937	3.625	0.625
3.750	3.500	4.625	5.062	3.625	0.625
3.875	3.750	4.750	5.187	3.750	0.625
4.000	3.875	4.875	5.312	3.750	0.625

# TYPE 1/1B

## ELASTOMER BELLOWS SEALS

### Basic Pressure Rating

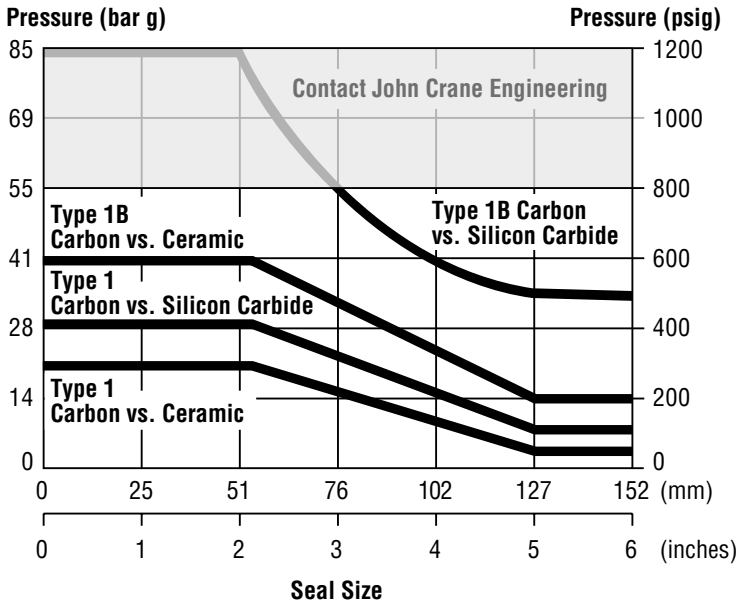

To determine the maximum pressure for the Type 1 or 1B required, multiply the maximum pressure by the multiplier factors to obtain the maximum operating pressure.

The basic pressure rating is based on a standard Type 1 or Type 1B seal installed according to the criteria given in this data sheet and according to generally accepted industrial practices. The basic pressure rating assumes stable operation at 1800 rpm in a clean, cool, lubricating, nonvolatile liquid, with an adequate flush rate. When used with the multiplier factors, the basic pressure rating can provide a conservative estimate of the dynamic pressure rating.

Contact John Crane for process services outside this range and with more detailed application information in order to obtain the actual dynamic pressure rating.

### Multiplier Factors

	Selection Considerations	Multiplier Factor
<b>Speed</b>	1800 rpm Above 1800 rpm	x 1.00 *
<b>Sealed Fluid Lubricity</b>	Petrol/Gasoline, Kerosene, or Better Water and Aqueous Solutions Flashing Hydrocarbons** (Specific Gravity <0.65)	x 1.00 x 0.75 x 0.60
<b>Sealed Fluid Temperature (for carbon only)</b>	Below 79°C/175°F From 79°C to 121°C/175°F to 250°F From 121°C to 177°C/250°F to 350°F Above 177°C/350°F	x 1.00 x 0.90 x 0.80 x 0.65

\* Multiplier = 1800/new speed    Example: If new speed = 2700 rpm  
Multiplier = 1800/2700 = 0.67

\*\* The ratio of sealed pressure to vapor pressure must be greater than 1.5, otherwise consult John Crane. If the specific gravity is less than 0.60, consult John Crane.

### Example for Determining Pressure Rating Limits

Seal: 76mm/3" diameter Type 1B

Product: Water

Face material: carbon vs. silicon carbide

Temperature: 16°C/60°F

Shaft Speed: 1800 rpm

Using the basic pressure rating chart, the maximum pressure would be 55 bar g/800 psig.

From the multiplier factors chart, apply the multipliers for the specific service requirements to determine the maximum dynamic pressure rating for the application.

55 bar g/800 psig x 1 x 0.75 x 1 = 41 bar g/600 psig

At 1800 rpm with the service conditions noted, a 76mm/3" diameter Type 1B seal has a dynamic pressure rating of 41 bar g/600 psig. If operating pressure exceeds this dynamic rating, consult your John Crane representative.

### Breakout (Starting) Torque Consumption for Seal

For starting torque power consumption, consult John Crane.

### Hydrostatic Pressure Limits

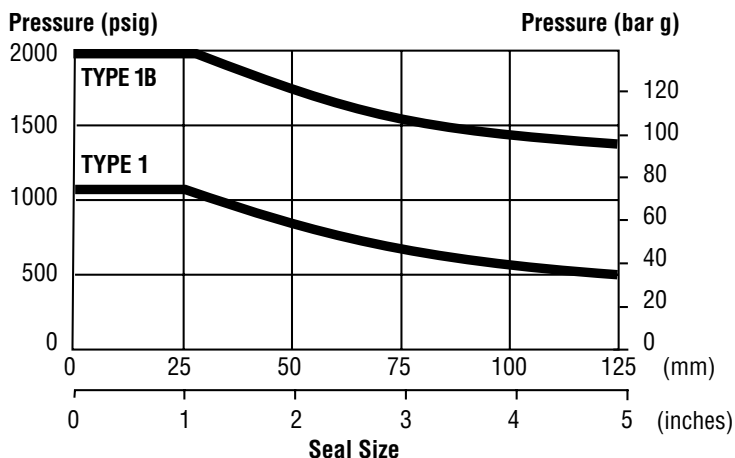

### Speed Limits for Coil Springs

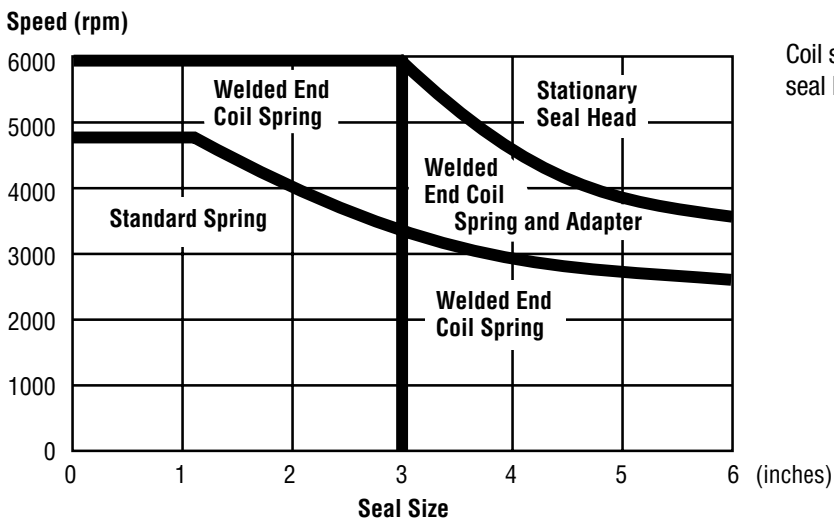

Coil spring requirements for rotating Type 1 and 1B seal heads with standard stuffing box diameter.

### Criteria for Installation

Shaft/Sleeve	Limits
Surface Finish	1.00" to 3.125" dia./63 Ra 3.125" dia. and up/32 Ra
Ovality/Out of Roundness (Shaft)	0.051mm/0.002"
End Play/Axial Float Allowance	±0.13mm/0.005"

**Angular and Radial Movement**

SEAL COMPONENTS	MATERIALS	
Description	Standard	Options
Face/Primary Ring	Carbon	Antimony-Impregnated Carbon Tungsten Carbide Silicon Carbide
Retainer Disc Drive Band Spring Holder	18-8 Stainless Steel	Monel® Alloy 20 CB-3 SS 316 Stainless Steel
Bellows	Buna-N	Aflas® Fluoroelastomer Ethylene Propylene Neoprene® (Chloroprene)
Springs	18-8 Stainless Steel	Monel Alloy 20 CB-3 SS 316 Stainless Steel

**Application Criteria**

Type 1/1B elastomer bellows seals can be customized for specific installations after review and evaluation by John Crane. The following data is needed to evaluate the proposed service:

- Make and model of equipment
- Shaft or sleeve outside diameter (OD)
- Direction of shaft rotation viewed from drive end
- Seal cavity dimensions
- Speed
- Process fluid
  - Specific gravity
  - Box pressure
  - Vapor pressure
  - Temperature
  - Viscosity

Aflas is a registered trademark of Asahi Glass Co., Ltd.

Monel is a registered trademark of Inco Alloys International, Inc.

Neoprene is a registered trademark of DuPont.

# TYPE 1/1B

## ELASTOMER BELLOWS SEALS

