

TYPE 1648/2648/3648

API 682 CATEGORY 2 AND 3, TYPE A PUSHER SEALS

Technical Specification

- A – Seat/Mating Ring
- B – Face/Primary Ring
- C – Sleeve
- D – Segmented Bushing Assembly
- E – Distributed Flush

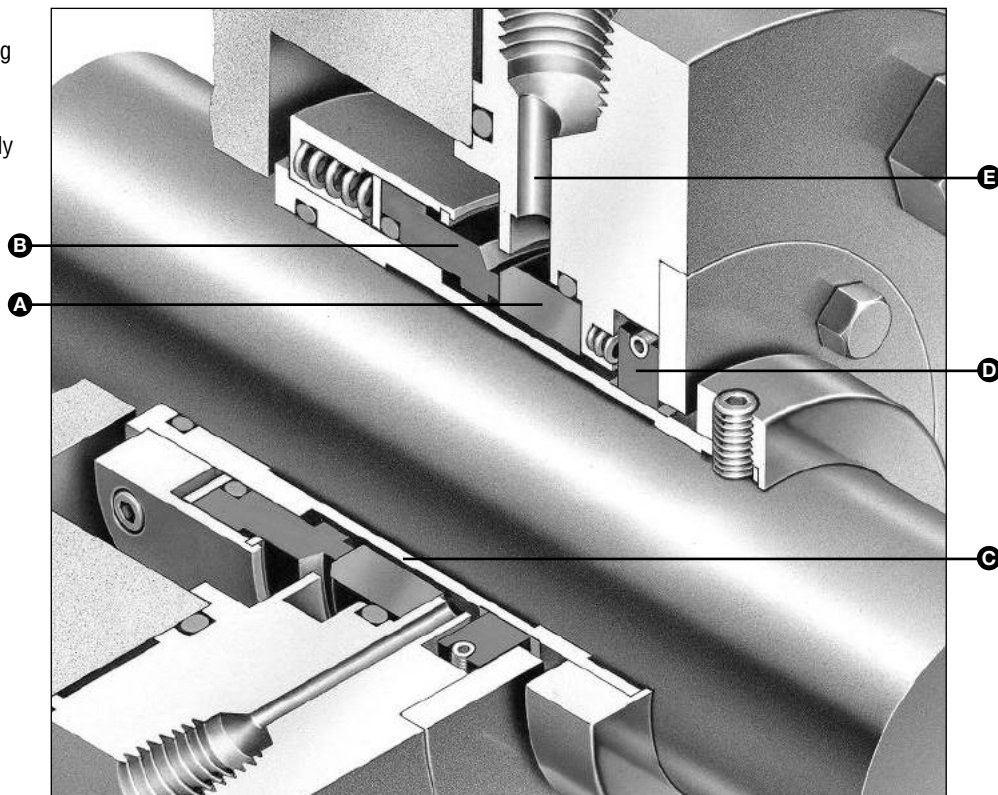

Type 1648 (Category 3 with segmented bushing and distributed flush shown)

Product Description

Type 1648 - Category 2, Type A, Arrangement 1 single cartridge seal. Available with either a fixed, floating or segmented bushing option and with either a single point or distributed flush arrangement.

Type 1648 - Category 3, Type A, Arrangement 1 single cartridge seal with segmented bushing and distributed flush standard. Provided with the appropriate documentation in accordance with API 682.

Type 2648 - Category 2, Type A, Arrangement 2 dual unpressurized cartridge seal. The outer seal provides additional containment in conjunction with an API Flush Plan 52.

Type 2648 - Category 3, Type A, Arrangement 2 dual unpressurized cartridge seal provided with the appropriate documentation in accordance with API 682.

Type 3648 - Category 2, Type A, Arrangement 3 dual pressurized cartridge seal. The inner seal is double-balanced to provide a positive seal with pressure from either direction. The outer seal contains the barrier fluid using an API Flush Plan 53 or 54.

Type 3648 - Category 3, Type A, Arrangement 3 dual pressurized cartridge seal provided with the appropriate documentation in accordance with API 682.

Design Features

- API 682 qualification tested
- Evolved from performance-proven Type 48 designs
- Easy-to-install cartridge design with registered fit
- Computer-optimized, low-emission seal faces
- Segmented spring-loaded carbon throttle bushing for effective containment (Type 1648)
- Distributed flush optimizes circulation of liquid at faces and prevents trapped vapor
- Available with pumping ring when utilizing an API Flush Plan 23 (Type 1648)
- Dual seals equipped with pumping ring for optimized flow
- Withstands reverse pressurization (Type 3648)

Performance Capabilities

- Temperature: -40°F to 500°F/-40°C to 260°C
- Pressure: up to 1000 psi(g)/69 bar(g) max.
- Speed: up to 5000 fpm/25 m/s
- Shaft size: 1.000" to 4.500"/25mm to 120mm

Typical Applications

- Hydrocarbons (heavy and light)
- Aromatic fractionation products (benzene, toluene, solvents, etc.)
- Crude oil fractionation products (fuel oil, lubricating oil, gasoline, etc.)
- Chemicals, caustics, some acids, aqueous solutions, lubricating liquids
- Industrial applications involved in the processing of volatile organic compounds (VOC) and similar hazardous products

TYPE 1648/2648/3648

API 682 CATEGORY 2 AND 3, TYPE A PUSHER SEALS

Technical Specification

Type 1648 - API Type A Arrangement 1 - Single Cartridge

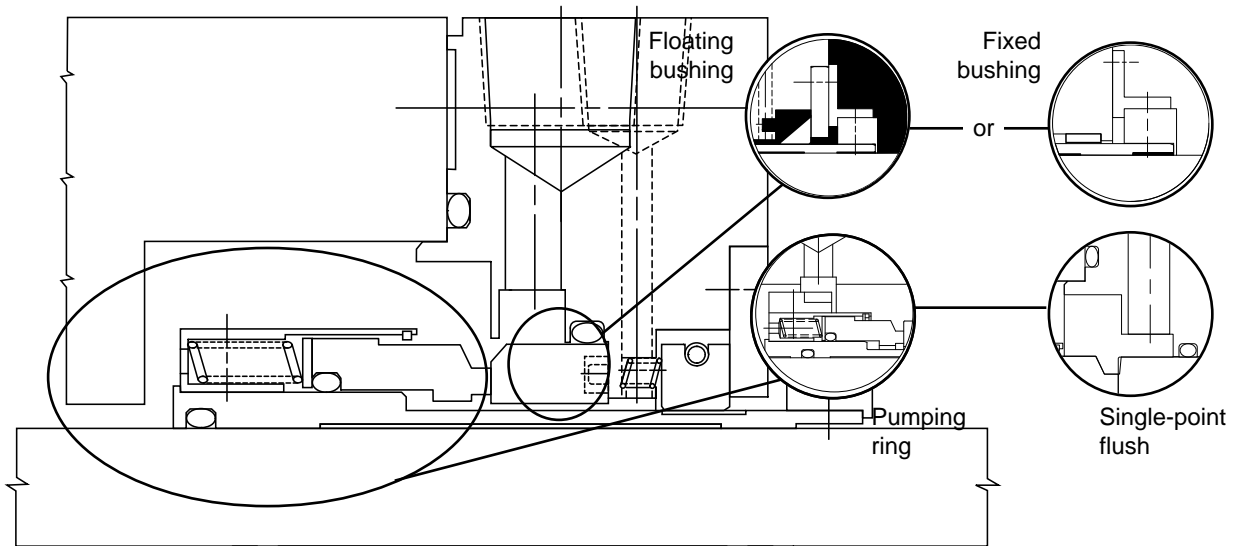

Type 2648 - API Type A Arrangement 2 - Dual Unpressurized Cartridge

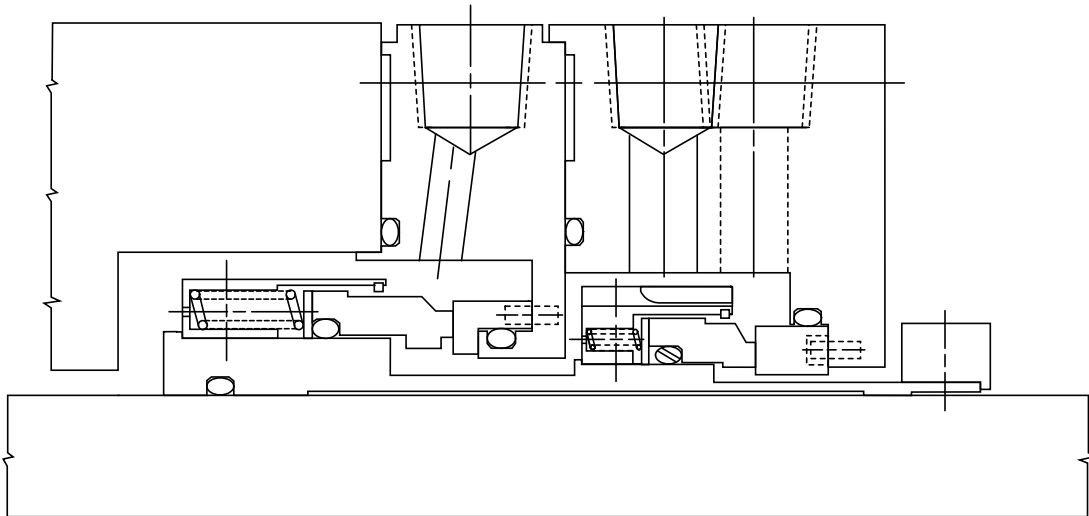

Type 3648 - API Type A Arrangement 3 - Dual Pressurized Cartridge

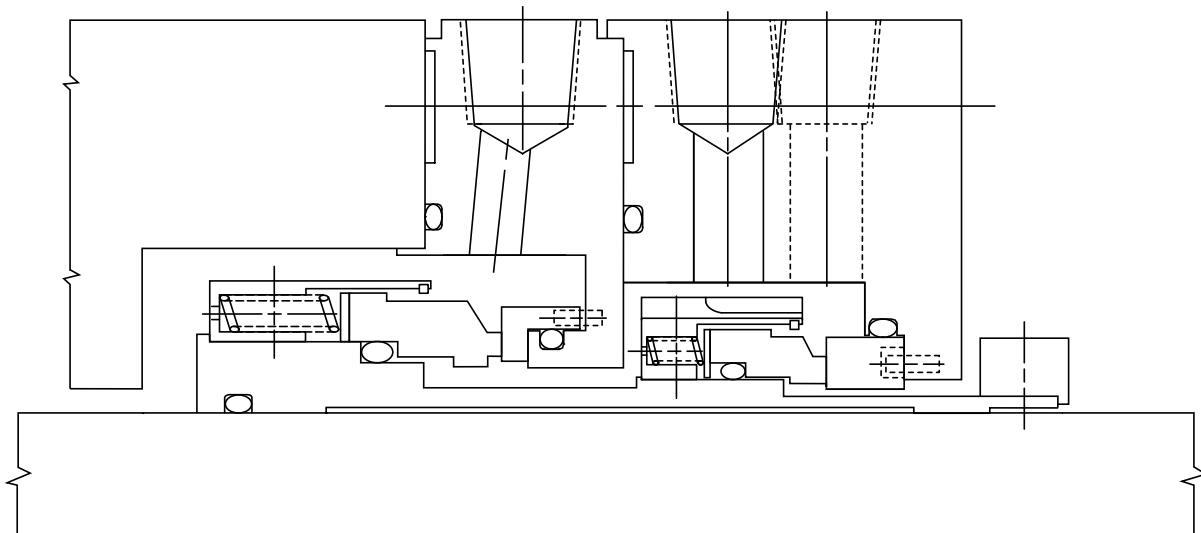

The Type 48 Seal Family

The primary default seal selection per API 682 is the Type A, multiple-spring pusher seal that is supplied in single, dual unpressurized and dual pressurized arrangements. The John Crane Type 48 is the seal on which our API 682 offering is based. The Type 48 family includes the following seals:

- Type 48LP - Balanced pusher seal with plain-face design for lower pressure applications. Used as a single, inboard seal on dual unpressurized arrangements and as an outboard seal on either dual pressurized or unpressurized arrangements.
- Type 48HPv - Balanced pusher seal, with hydropad face design to enhance face lubrication, incorporates a hammerhead design to increase stiffness for high pressure designs. Used as a single, inboard seal on dual unpressurized arrangements, and occasionally as an outboard seal on dual pressurized arrangements.
- Type 48RP - Double balanced pusher seal primarily designed for ID pressure applications. Commonly referred to as a reverse-pressure design. Used as an inboard seal on dual pressurized arrangements and occasionally as an inboard seal on dual unpressurized arrangements.
- Type S48 - Shorter balanced seal designed for OD pressures only. Used as an outboard seal on either dual unpressurized or dual pressurized arrangements.

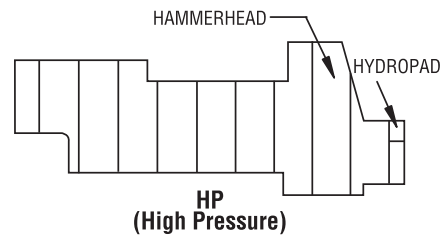
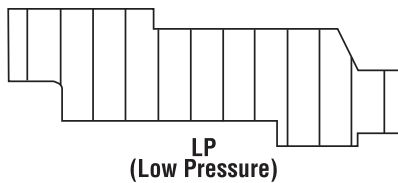

Multiplier Factors

	Selection Considerations	Multiplier Factor
Sealed Fluid Temperature	Below 175°F/80°C	x 1.00
	Above 175°F to 250°F/80°C to 125°C	x 0.90
	Above 250°F to 350°F/125°C to 180°C	x 0.80
	Above 350°F/180°C	x 0.65
Materials	Tungsten Carbide vs. Silicon Carbide	x 0.50

Example for Determining Pressure Rating Limits:

Seal: 3"/75mm Diameter Type 48LP

Product: Lube Oil

Temperature: 180°F/82°C

Speed: 3600 rpm

Using the Type 48LP pressure ratings limit graph, the pressure limit is 645 psi(g)/44.5 bar(g). From the multiplier factors chart, apply the appropriate value, in this case 0.90. For this service condition, the maximum operating pressure is:

$$645 \text{ psi(g)} \times 0.90 = 580.5 \text{ psi(g)/40 bar(g)}$$

Notes:

1. The above temperature derating factors apply to seals with carbon primary rings only, not hard face vs. hard face combinations.
2. The temperatures noted are product temperatures for single seals or the expected average temperature of the product and buffer/barrier fluid for dual seals.

TYPE 1648/2648/3648

API 682 CATEGORY 2 AND 3, TYPE A PUSHER SEALS

L-Shaped Mating Ring Internal Pressure Limits

The L-shaped mating ring used for dual seal arrangements is designed to be hydraulically balanced when used with the proper seal size. The pressure limit of the mating ring should be considered along with the seal head pressure limit when selecting dual seal arrangements.

The pressure limit with outside diameter (OD) pressure is 830 psi(g)/57.2 bar(g) for Silicon Carbide. This chart shows the inside diameter (ID) pressure limit for the Silicon Carbide mating ring.

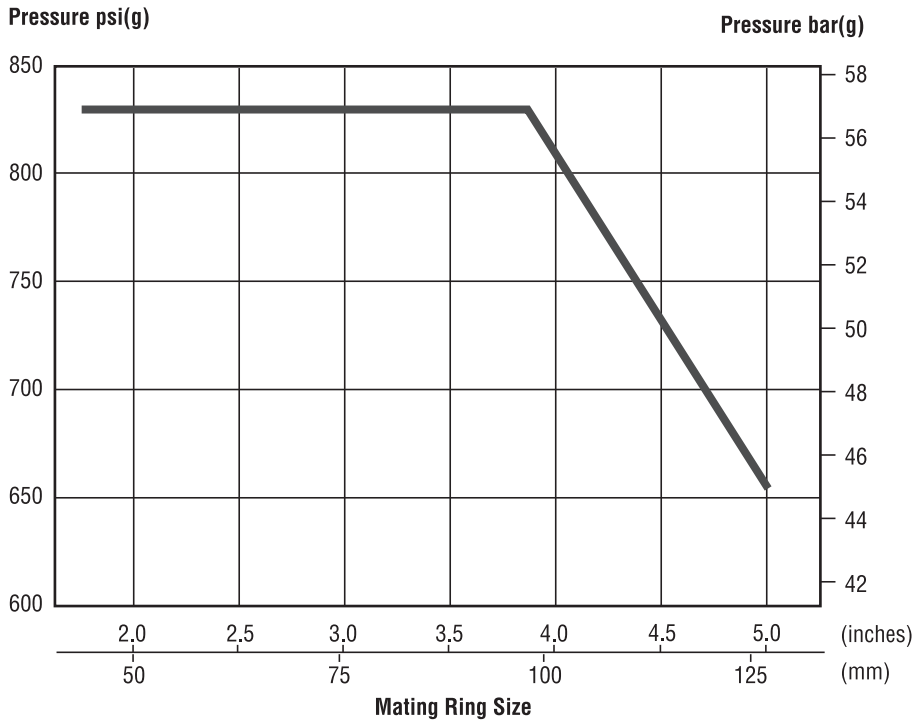

Type 48 Series Hydrostatic/Static Pressure Limits

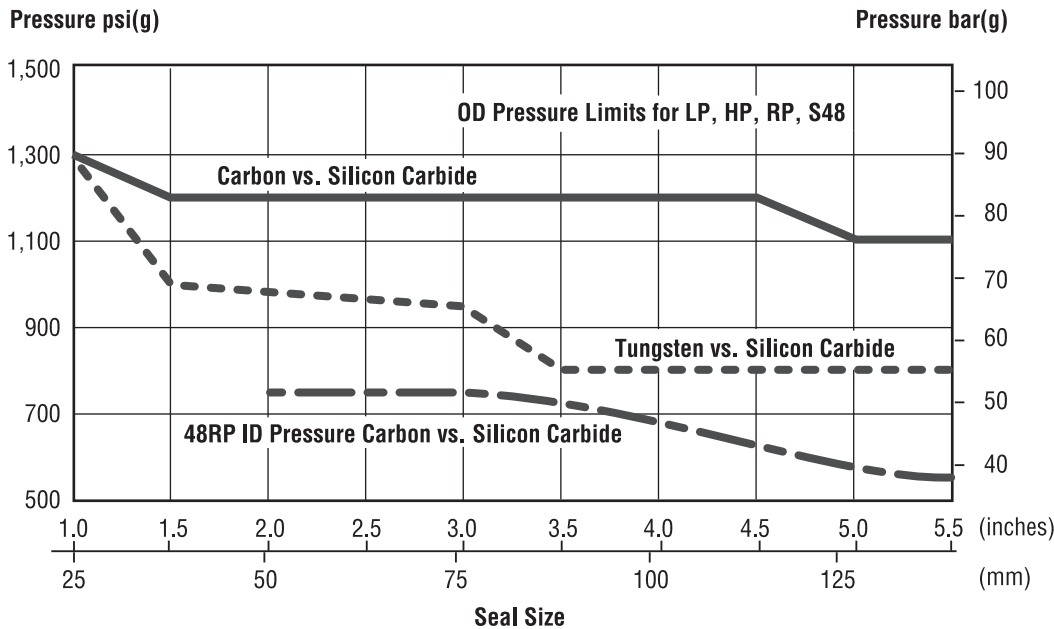

NOTE: Maximum static sealing pressure should be greater than the two values below:

1. Hydrostatic pressure limit (divided by) 1.5
2. Maximum dynamic sealing pressure

TYPE 1648/2648/3648

API 682 CATEGORY 2 AND 3, TYPE A PUSHER SEALS

Pressure Limits

Carbon vs. reaction-bonded silicon carbide

Other application-specific limits may apply. Contact John Crane for application assistance.

Type 48LP

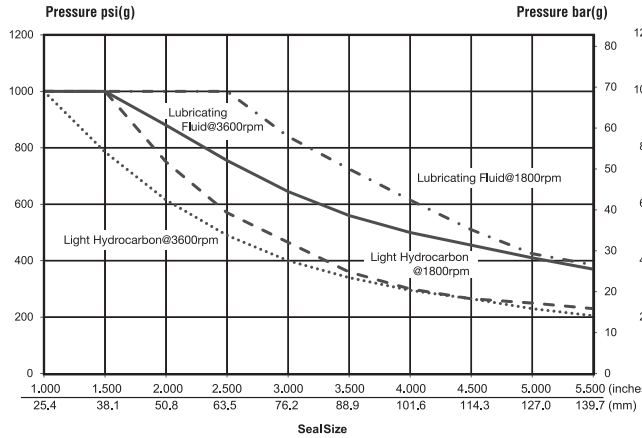

Type 48HP

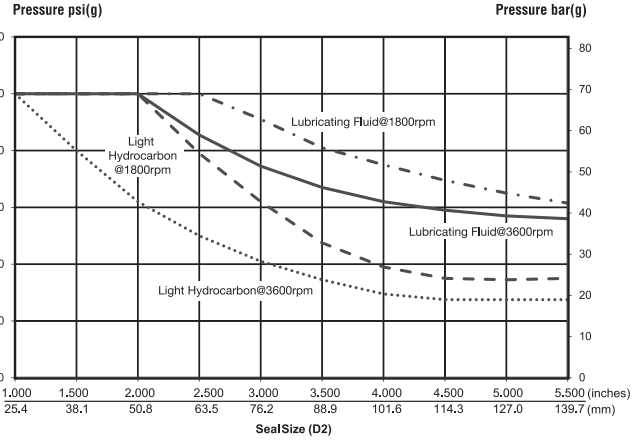

Type S48

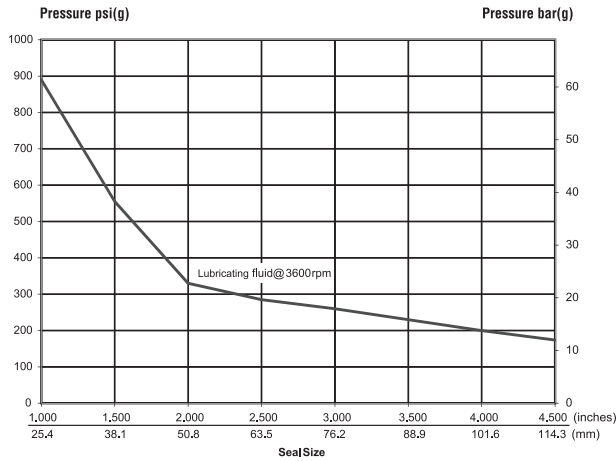

Type 48RP OD Pressure

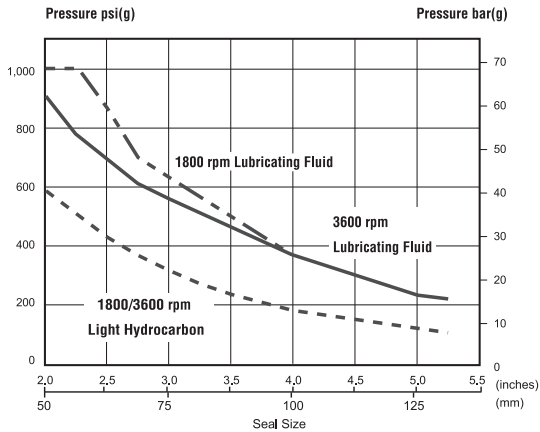

Type 48RP ID Pressure

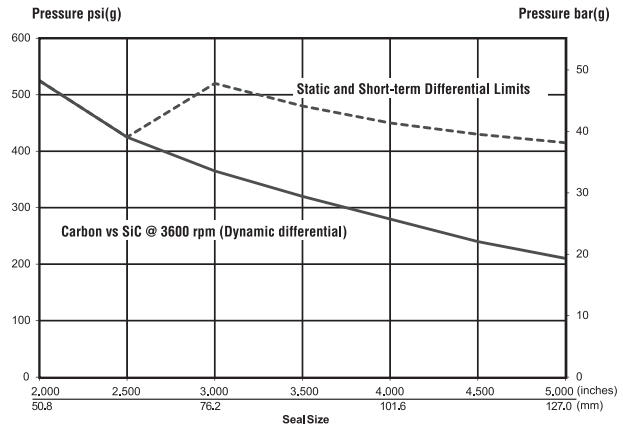

Materials of Construction

SEAL COMPONENTS	MATERIALS	
	Description	Standard
Face/Primary Ring	Antimony Carbon	Nickel Binder Tungsten Carbide Alpha Sintered Silicon Carbide Resin Carbon
Seat/Mating Ring	Reaction Bonded Silicon Carbide	Alpha Sintered Silicon Carbide
Retainer Disc Snap Screw Set Screw Sleeve Collar Segmented Bushing Gland Plate Auxiliary Gland	316 Stainless Steel	—
Spring	Alloy C-276 (UNS N10276)	316 Stainless Steel (Single Spring Only)
O-Ring	Fluoroelastomer	Amine-Resistant Perfluoroelastomer Low Temp Buna-N Perfluoroelastomer

Angular and Radial Movement

Excessive runout will have a detrimental effect on seal performance in the form of component wear or excessive leakage. API 682 limits runout as follows:

- Centering of the seal is to be by a register fit. The register fit surface shall be concentric to the shaft and have a total indicated runout (TIR) of not more than 0.005"/125 micrometers.
- Squareness of the seal chamber face to the shaft shall not exceed 0.0005" per inch of seal chamber bore (15 micrometers/3cm).
- Runout of the sleeve outer diameter to the inner diameter shall be 0.001"/25 micrometers TIR.