

- A - Mating ring
- B - Primary ring
- C - Quench seal
- D - V-ring
- E - U-cup
- F - Sleeve
- G - Drive disc
- H - Spiral retaining ring
- I - Gland plate
- J - Drive collar

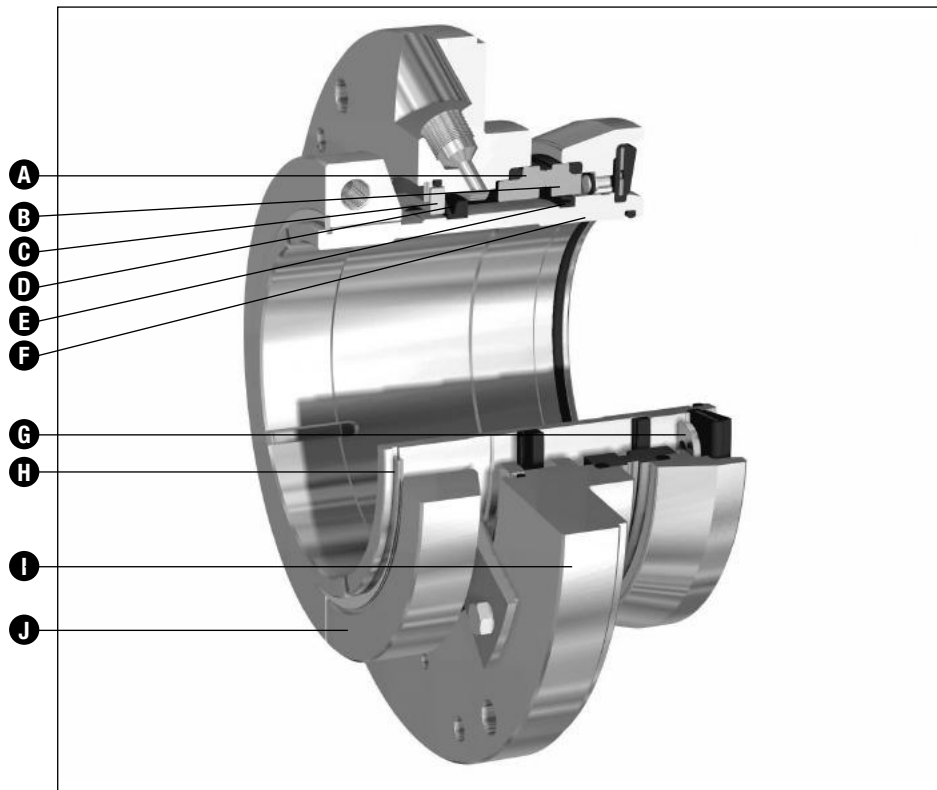

Product Description

Type 5840 is a cartridge seal design, suitable for abrasive slurry duties and capable of operating without a quench. A modular construction incorporates a cone spring which avoids clogging and eliminates the dynamic O-ring and risk of hang-up. Seal faces are silicon or tungsten carbide and identical. Adaptive hardware is alloyed stainless steel or high chrome iron to provide both excellent corrosion and abrasive resistance of wetted components. A quench seal option available to improve service life.

Performance Capabilities

- Temperature: up to 167°F/75°C without quench
up to 248°F/120°C with quench
- Pressure: up to 300 psi(g)/21 bar(g)
- Speed: 0 to 3600 rpm
3000 fpm/15 m/s

For conditions other than those listed above, please consult John Crane.

Design Features

- Robust cartridge arrangement, with six (6) group sizes
- Accommodates shafts 1.37" to 8.66"/35mm to 220mm
- Modular construction for reduced inventory and ease of reconditioning
- Hydraulically balanced design with interchangeable seal faces
- Abrasion resistant seal faces in silicon or tungsten carbide
- Non-clogging cone spring eliminates dynamic O-rings
- TFE/P standard elastomers
- No flush is required
- Anti-rotation pin with O-ring

TYPE 5840

CARTRIDGE SLURRY SEAL

Type 5840 Typical Arrangement

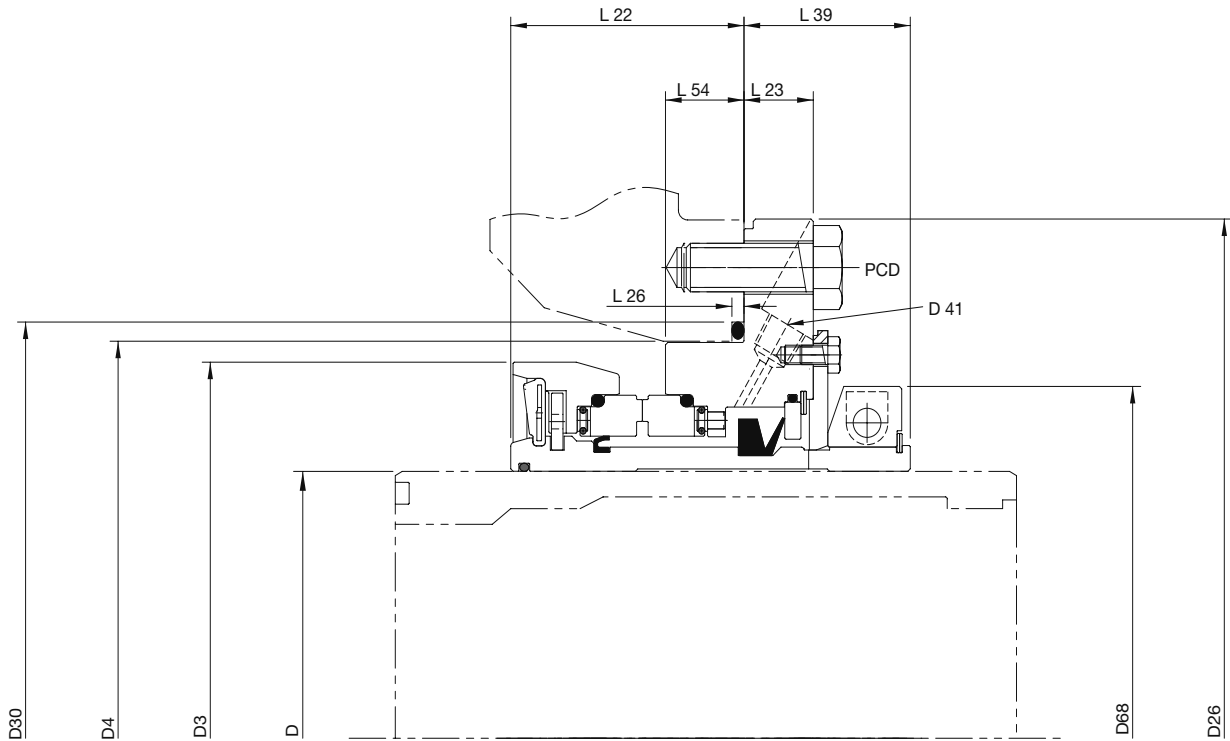

Type 5840 Dimensional Data (mm)

Group	D	D3	D4	D26	D30	D41	D68	L22	L23	L26	L39	Gland Stud PCD	Stud Dia
1	35 - 51	99.0	n/a	140.0	133.0	1/4" NPT	63.0	42.0	24.3	n/a	37.0	n/a	n/a
2	51 - 82.5	136.0	163.0	217.0	172.7	1/4" NPT	113.0	54.5	25.0	2.81	45.0	195.0	M12
3	82.5 - 105	170.0	185.0	243.0	200.6	1/4" NPT	154.0	69.5	21.0	4.33	59.0	220.0	M12
4	105 - 135	204.0	210.0	288.0	225.6	3/8" NPT	196.0	69.5	27.0	4.33	67.0	260.0	M12
5	135 - 180	258.0	270.0	350.0	285.8	3/8" NPT	235.0	86.5	25.0	5.52	67.0	320.0	M12
6	180 - 220	310.0	327.3	428.0	343.1	3/8" NPT	290.0	101.0	30.0	5.23	72.0	388.0	M20

Type 5840 Dimensional Data (inches)

Group	D	D3	D4	D26	D30	D41	D68	L22	L23	L26	L39	Gland Stud PCD	Stud Dia
1	1.375 - 2.000	3.898	n/a	4.961	5.236	1/4" NPT	2.480	1.654	0.957	n/a	1.457	n/a	n/a
2	2.000 - 3.250	5.354	6.419	8.543	6.799	1/4" NPT	4.449	2.146	0.984	0.110	1.772	7.677	M12
3	3.250 - 4.125	6.693	7.285	9.567	7.898	1/4" NPT	6.063	2.736	0.827	0.171	2.323	8.661	M12
4	4.125 - 5.313	8.032	8.269	11.339	8.882	3/8" NPT	7.717	2.736	1.063	0.171	2.638	10.236	M12
5	5.313 - 7.063	10.157	10.632	13.780	11.250	3/8" NPT	9.252	3.406	0.984	0.217	2.638	12.598	M12
6	7.063 - 8.625	12.205	12.885	16.850	13.507	3/8" NPT	11.417	3.976	1.181	0.206	2.835	15.276	M20

Seal Pressure Rating

For seal sizes up to 7.09"/180mm, the dynamic pressure rating is 300 psi(g)/21 bar(g).

For larger seals up to 8.66"/220mm the pressure is limit is 218 psi(g)/15 bar(g), for applications over 10 bar(g) please consult John Crane.

The maximum static pressure rating is 435 psi(g)/ 30 bar(g), for seal sizes up to 7.09"/180mm and 300 psi(g)/21 bar(g) for larger seals up to 8.66"/220mm.

Type 5840 Speed & Pressure Rating (Metric)

Type 5840 Speed & Pressure Rating (Imperial)

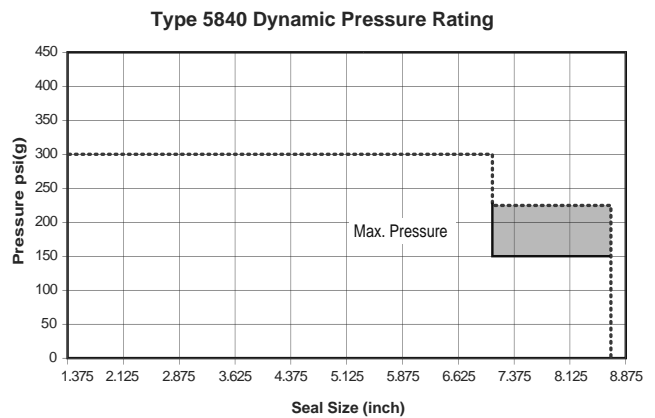
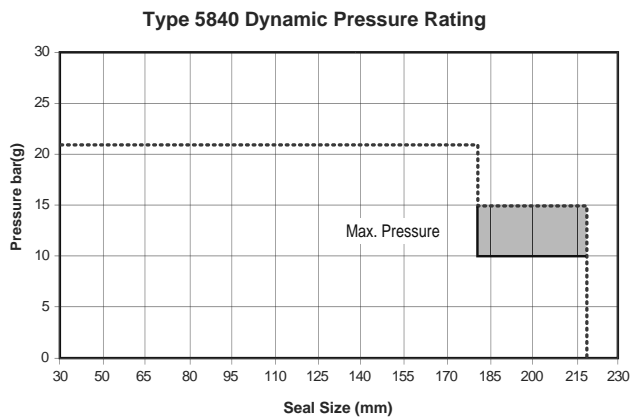
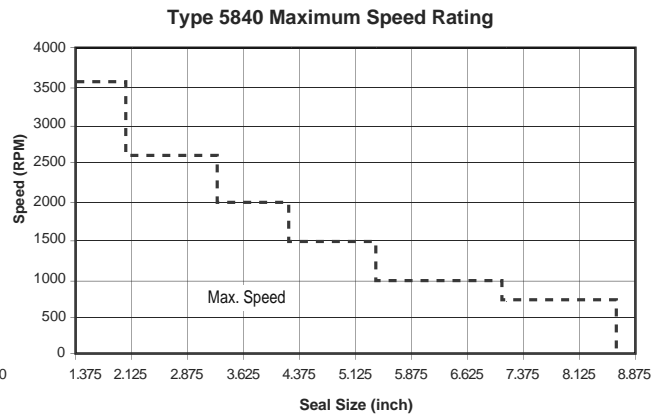
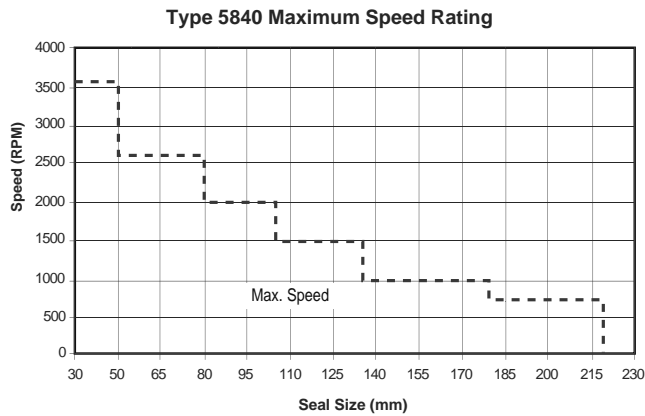

* For sizes over 7.087"/180mm consult John Crane for pressures over 145 psi(g)/10 bar(g)

Materials of Construction

DESCRIPTION	STANDARD MATERIAL	OPTIONAL MATERIAL
Gland Plate Shaft Sleeve Primary Ring Carrier	Duplex Stainless Steel (wrought) CD4MCU-N Cast	Super Duplex 28% Hard Chrome Iron (1.436/1.438) Alloy C-276
Drive Collar	316 Stainless Steel	304 Stainless Steel Duplex Stainless Steel
Cone Spring	AFLAS® (TFE/P)	
Primary Ring Mating Ring	Silicon Carbide	Tungsten Carbide (to 5.715"/135mm)
Secondary Containment Mating Ring	Tungsten Carbide	
Soc. HD. Capscrew	Alloy Steel (Grade 12.9) Zinc PLT	
Spiral Retaining Ring	302 Stainless Steel	
Setting Piece	316 Stainless Steel	304 Stainless Steel
Hex. HD. Screws Pin Drive Disc	316 Stainless Steel	
Elastomer	AFLAS® (TFE/P)	

*AFLAS® is a registered trademark of the Asahi Glass Co., Ltd.