



i-matic

ACTUATORS WITH INTEGRATED CONTROL
AND NON-INTRUSIVE SETTING

DREHMO
VALVE ACTUATORS

Valve actuators for multiple applications

Wherever material flows through pipelines in liquid, gas or powder form, several kinds of valves are used to shut off or to regulate the rate of flow or pressure. For reliable remote operation of these valves, whether they be globe, gate, ball or butterfly valves or dampers, DREHMO have been successfully employed electromechanical actuators all over the world for several decades.



DREHMO actuators are used in power generation, water industry, oil and gas market as well as chemical and petrochemical process industry. Actuators have to move the valve to a mechanically defined final position or to intermediate positions and avoid excessive torque



that overload the valve during travel between the final positions. According to this special devices ensure that the actuator is switched off in dependence of the position, angle of rotation or torque. Special variants include part-turn actuators and thrust actuators, which transform the torque into an axial thrust by means of a thrust unit.

In plant areas in which explosive gases may be present, actuators have type-tested and certified for explosion protection. The variety of torques and actuator speeds required in practice is met by a wide range of DREHMO actuators. DREHMO actuators can be fitted with torque and position sensor and signal processing systems to suit the various remote control requirements. The following product lines are available for this purpose:

- > **S-RANGE ACTUATORS**
with limit and torque switches
- > **C-MATIC ACTUATORS**
with integrated control unit
- > **I-MATIC ACTUATORS**
with smart integrated control unit and non-intrusive settings as well as predictive maintenance features.
x-matic actuators are especially designed i-matic types for the oil & gas industry.
These are enhanced by a flameproof enclosure.



DREHMO i-matic

... with integrated control unit and non-intrusive setting and parameterisation

i-matic actuators are high-end sophisticated actuators. The actuators are operated via user interface with LC-Display and push-buttons. They include an integrated control unit and a variety of programmable actuator functions and operating modes via remote and local settings, watchdog, electronic nameplate, datalogger as well as local valve diagnostics for predictive maintenance.

BASICS:

- > DREHMO 3-phase AC squirrel cage motor, insulation class F, 3 thermoswitches
- > Combined sensor for limit and torque sensing
- > Controls:
 - Switchgear: Interlocked reversing contactors (mechanically and electrically locked)
 - Control: 24V DC, 4 digital inputs (programmable commands, potential-free)
 - Feedback: 6 normally open contacts and 1 change-over digital output (programmable signals, potential-free)
- > Local controls:
 - 4 multi-function push buttons
Modes: LOCAL - OFF - REMOTE - LEARN
Menu Navigation: UP, ESCAPE, DOWN, ENTER,
Operation: OPEN - STOP - CLOSE
 - 5 indications with selectable colours
 - Interface: Bluetooth
- > Enclosure protection IP68 according to IEC 60529
- > Ambient temperature -25°C up to +70 °C
- > Handwheel for manual operation/without switch-over mechanism
- > Electrical connection: plug/socket connector with screw-type connection

Overview

MULTI-TURN ACTUATORS



The design principle of multi-turn actuators is to turn a multiple of 360 degrees at the output drive.

They are designed to operate valves with 2 up to 1450 revolutions per stroke.

Multi-turn actuators are fitted mainly to gate and globe valves which transform the multiple rotation of the actuator's output drive into linear movement via a threaded spindle.

Flanges and output drive designs of the multi-turn actuators are standardized in accordance with DIN EN ISO 5210 or DIN 3210 respectively and therefore fit on any modern valve design.

Furthermore a multitude of special flange designs is available. The multi-turn actuators are classified in four housing sizes according to their rated torque:

- 10 Nm to 60 Nm:
actuator size DiM 30, 59
- 60 Nm - 250 Nm:
actuator size DiM 60, 120, 249
- 250 Nm - 1000 Nm:
actuator size DiM 250, 500, 1000
- 1000 Nm - 2000 Nm:
actuator size DiM 2000

Torque values exceeding 2000 Nm are realized by additional spur or bevel gearboxes.

PART-TURN ACTUATORS



Part-turn actuators are a special type of multi-turn actuator for operating butterfly, ball valves or damper, for instance, with an output drive movement of less than 360°. The internal gear of the part-turn actuator is designed for a travel range in between 75° and 105°.

The mechanical design of the part-turn actuators DPiM(R) 75 - 1800 is based on a multi-turn actuator with an additional attached planetary gear stage.

The flange dimensions and the different output drives, such as plug bush with bore and groove and square bore, all correspond to the usual standards, e.g. DIN EN ISO 5211. This means that direct mounting on the valve is possible. Accessories such as foot and lever with ball joints make indirect operation of butterfly valves possible depending on the structural and design conditions of the valves.

Torque values exceeding 1800 Nm are realized by multi-turn actuators with additional worm gearboxes.

THRUST ACTUATORS



DREHMO thrust actuators can be fitted to valves which require a linear movement. The thrust actuator transforms the torque of a DREHMO multi-turn actuator into an axial thrust by means of an attached thrust unit. The required actuating force (thrust or traction) can be adjusted continuously and reproducibly.

Thrust units fitted to the flange of a multi-turn actuator consist mainly of a trapezoidal threaded spindle, a metric screw bolt to join the valve shaft and an enclosure to protect the spindle from environmental influences. The version described is used for direct mounting of the actuator to the valve. However, "fork joint" versions of the thrust actuators (indirect mounting) primarily operate butterfly valves for which direct mounting of a 90° part turn actuator is not possible or efficient for design reasons.

Cardanic suspension of the thrust unit at the fork joint is also available.



**OPERATION MODES –
OPEN-CLOSE, POSITIONING AND MODULATING DUTY**

Valves are driven in compliance with the required application and their design. Actuator standard EN 15714-2 distinguishes between three cases:

> **Class A: OPEN-CLOSE duty**

The actuator is required to drive the valve through its entire travel from the fully open position to the fully closed position or vice versa.

> **Class B: Inching or positioning duty**

The actuator is required to occasionally drive the valve to any position (fully open, intermediate and fully closed).

> **Class C: Modulating duty**

The actuator is required to frequently drive the valve to any position between fully open and fully closed.

SWITCHING FREQUENCY AND MOTOR OPERATION MODE

Between Modulating duty and open-close duty there are differences regarding to the mechanical loads. Consequently, special actuator types are available for each operation mode.

The types of duty for actuators in compliance with DIN EN 60034-1 and EN 15714-2 are typical distinction criteria.

For modulating duty, additional indication is made of the permissible number of starts.

ACTUATORS FOR OPEN-CLOSE DUTY AND POSITIONING DUTY

(classes A and B or types of duty S2 - 10 min/15 min)

DREHMO actuators for open-close and positioning duty are identified by type designations DiM:

- > DiM 30 - DiM 2000
- > DPiM 75 - DPiM 1800

ACTUATORS FOR MODULATING DUTY

(class C or types of duty S4 - up to 35%)

DREHMO actuators for modulating duty can be identified by type designations DiM R:

- > DiM R 30 - DiM R 2000
- > DPiM R 75 - DPiM R 1800

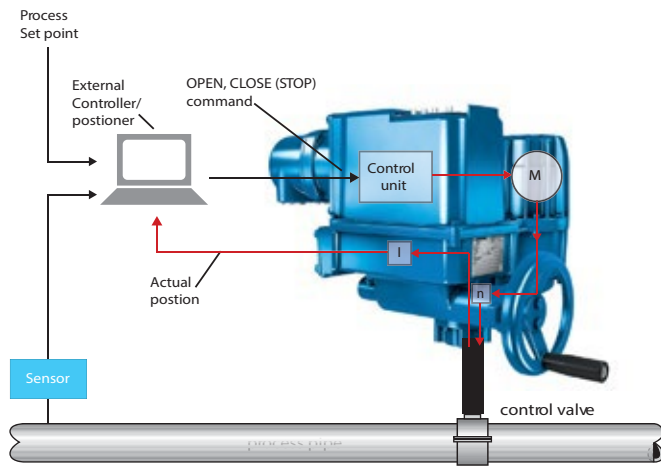

Actuators with external positioner for modulating duty.

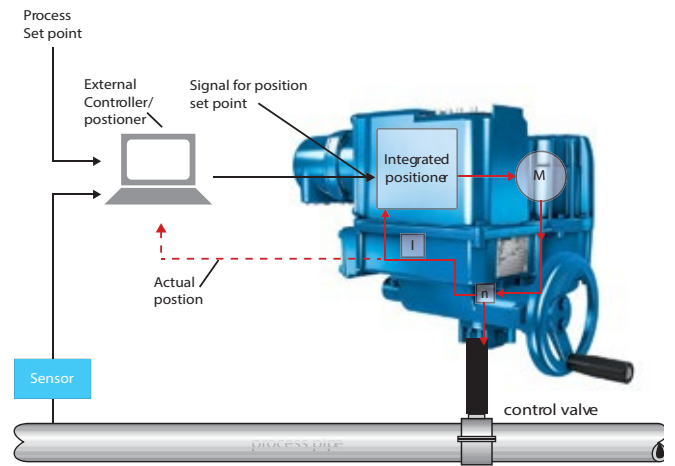

Actuators with integrated positioner for modulating duty.

Gear design and operating functions

The DREHMO actuators basically consist of a motor, planetary gear arranged with a torque-bearing displacement worm, a handwheel and an integrated control unit. All parts of the planetary gear are arranged around the hollow shaft. As several teeth always mesh simultaneously with this planetary gear (unlike normal worm gears), it is possible to realize a very compact gear with a long service life.

FUNCTIONALITY OF MANUAL OPERATION

Changeover from motorized to manual operation is not necessary. During manual operation via the handwheel, the forces are transmitted via the worm shaft (9), the sun wheel (11) and the planet wheel (4) to the driver plate (5), the hollow shaft (10) and the stem nut (6).

FUNCTIONALITY OF MOTOR OPERATION

The motor (1) drives the eccentric (3) via the spur gear (2). The planet wheel (4), which meshes into the inner gear of the sun wheel (11), is pivoted on the eccentric (3). As the two wheels have a different number of teeth, a relative speed is generated which is transferred by driver pins (12) to the driver plate (5). The driver plate (5) is interlocked with the hollow shaft (10) via serration.

TORQUE MEASUREMENT

In addition to the inner gear tooth system, the sun wheel (11) also has an outer gear tooth system which meshes with the axially displaceable worm shaft (9). The worm shaft (9) is held in its central position by a pretensioned spring (7). If a torque is exerted on the actuator higher than the torque created by the pretensioned springs, the peripheral force on the sun wheel (11) moves the worm shaft (9) from its central position and thereby actuates the torque lever (8). The torque lever (8) activates the combined sensor (15). The related torque values can be used for the remote torque feedback indication.

FEATURES OF THE ECCENTRIC PLANETARY GEAR

- Lifetime lubrication
- No mechanical switchover for handwheel operation is required
- No starting problems, even at low temperatures
- Long service life, even in modulating operation, due to low surface pressure combined with little relative movement between the meshing gears and optimum lubrication
- Can be mounted in any position
- Selflocking (up to 80 rpm at 50 Hz and up to 96 rpm at 60 Hz)

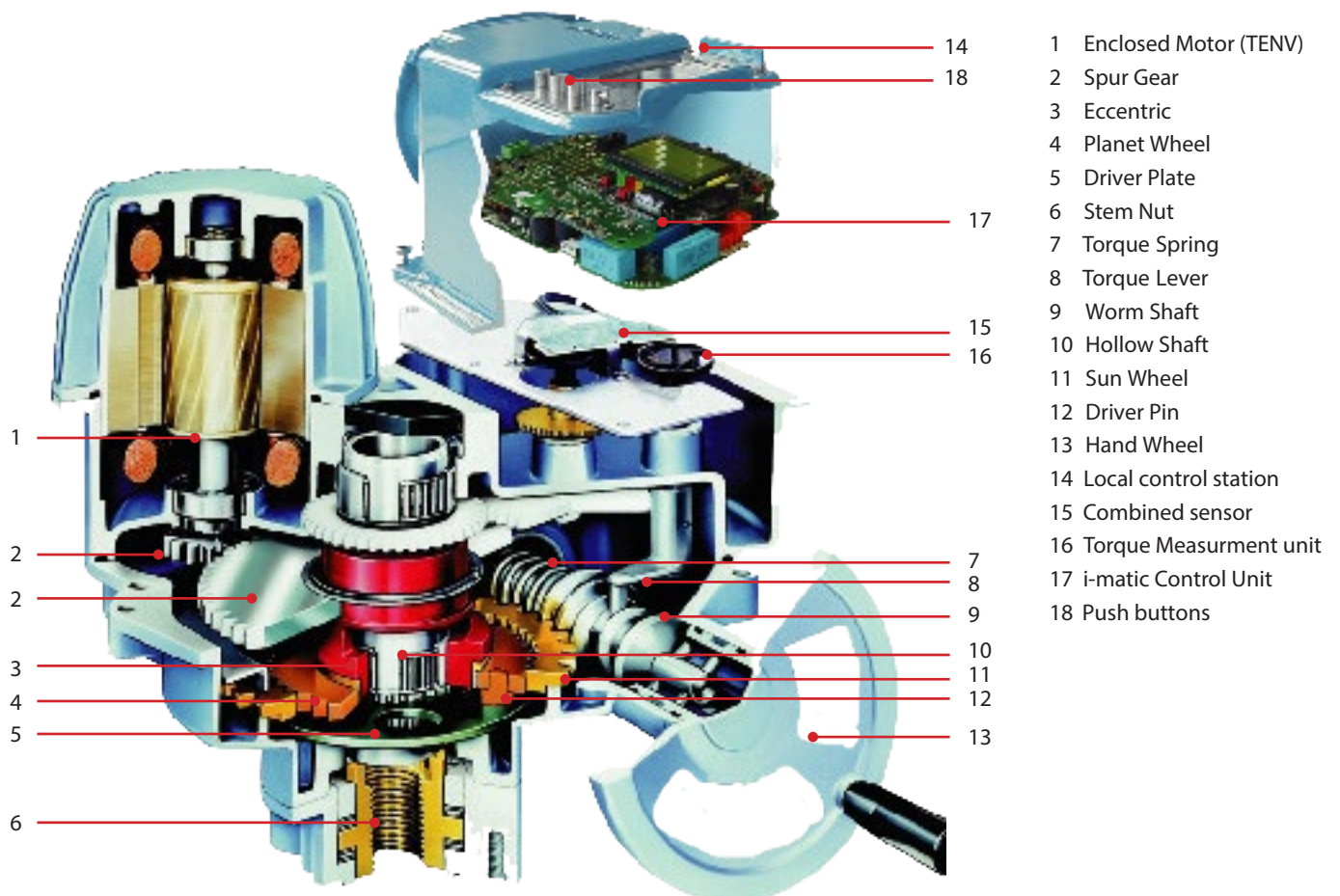



Characteristic features

GEAR DESIGN

The eccentric planetary gears are self-locking at all speeds up to 80/96 rpm, also at manual operation.

Low surface loading of gear-tooth system because several teeth are always in mesh. Long life time is guaranteed because of permanent lubrication and air-tight oil chamber, therefore the oil cannot oxidise.

Some high speed variants and all DiM 2000 models use a differing high efficient planetary gear design without self-locking. Self-locking and operation via handwheel require the use of a brake motor. The brake is designed as holding brake. Pulling loads greater than the maximum adjustable torque can't be dynamically stopped.

MANUAL OPERATION

As the handwheel is always in operation, manual operation is possible even if the equipment is temporarily seized e.g. if a valve is jammed in the end position.

The handwheel can be operated remotely without difficulty for inaccessible actuators via corresponding linkages and bevel gears.

COMBINED SENSOR

An electronic position sensor is used for continuous position detection, including the detection of intermediate positions. Interacting with the i-matic control unit, the sensor switches off the actuator when it reaches limit positions that have been electronically programmed and are nonerasable.

At the same time the sensor can supply isolated limit position signals and an analogue 4-20 mA position signal. A second measuring input is used to make an analogue recording of the torque reached, which is then compared and evaluated with settable switch-off values in the control unit. Analogue measurement, signalling and evaluation of the torque is possible while the actuator is running.

TENV MOTORS

DREHMO actuators are fitted with Totally Enclosed Non-ventilated Motors (TENV – 3-phase asynchronous motor) as standard. The motor housing is totally enclosed. This design guarantees the greatest possible protection against humidity and dust ingress and is therefore suitable for operation in extreme environmental conditions.

Operating mode:

Short-time duty S2 – 10/15 min; in modulating operation, S4 intermittent service max. 35 % ED. Insulation class F.

IEC MOTORS AND SPECIAL MOTORS

Standard motors, such as single-phase or DC motors, can be supplied on request instead of TENV motors.

MOTOR PROTECTION

Three thermal switches connected in series are mounted in each of the motor windings individually. In case of the motor temperature exceeding 155 °C the control circuit is interrupted. The contact to open the unit is integrated within the i-matic control unit. Failure indication is provided for DCS.

MECHANICAL COUPLING TYPES

Multi-turn actuators: Matched to the valve using coupling types and flange dimensions in accordance with DIN EN ISO 5210 or DIN 3210. Hollow shaft for ascending valve spindle.

Coupling types: stem nut, plug bush, bore with keyway, claw coupling, free shaft extension. Special designs for special installation conditions are possible.

Part-turn actuators: Coupling types and flange dimensions in accordance with DIN EN ISO 5211. Coupling types: bore with keyway, dihedron, square bore.

Thrust actuators: Coupling type in accordance with DIN 3358.

ELECTRICAL CONNECTION

Electrical connection is accomplished by means of a plug/socket connector which connects the control and signal wires as well as the power supply. Method of connection is screw terminals for control signals and for power supply.

LUBRICATION

Each actuator is factory filled with lifetime lubrication.

MOUNTING POSITION

Mounting and operation in any position permitted.

AMBIENT TEMPERATURES

Basic design:

-25 °C to + 70 °C (S2-Operation)

-25 °C to + 60 °C (S4-Operation)

ENCLOSURE TYPE

According to EN 60529 and EN 60034 DREHMO actuators with enclosed motors are supplied as standard with enclosure type IP 68 (5 m for 24 h).

PAINT COATING, CORROSION PROTECTION

Standard colour: RAL5015 (skyblue)

According to EN ISO12944-2 we have rated our corrosion protection system as follow:

K 3: for operation in occasionally aggressive atmospheres => C3

K 4: for operation in permanently aggressive atmospheres => C4

K 5: for operation in extremely aggressive atmospheres, such as off-shore platforms or cooling towers. => C5-M, C5-I

Other protection grades and colours on request.

CE-CONFORMITY

DREHMO actuators comply with the EC Machinery Directive 2006/42/EG, EC Low-Voltage Directive 2014/35/EU and the EMC Directive 2014/30/EU.

Features

SELF-MONITORING

A self-monitoring process runs continuously in the actuator. To simplify troubleshooting, the process distinguishes between the following messages:

- > Hardware fault
- > Sensor fault
- > Electronics fault
- > Software fault
- > Electronics temperature exceeded
- > Motor temperature exceeded

All malfunctions that occur are recorded chronologically in an error log.

COMMISSIONING / NON-INTRUSIVE CALIBRATION

The local control station consists of a graphical LC-Display, 4 buttons and a bluetooth interface. The actuator can be set and parameterized locally via the push-buttons (alternative operating via magnetic pen) without opening the control housing.

With a clearly structured menu navigation, the setting values can be easily aligned to the valve. Furthermore, all parameters of the actuator can be set easily. To prevent operating errors and manipulation, access to the commissioning mode can be protected with a password.

FAIL-SAFE

Should the external reference signal fail or the bus communication break-down, a user-definable fail-safe position can be set in line with process requirements or, if the parameter "fail as is" is selected, the actuator can be arrested in the current position.

DATA MEMORY

Actuator-specific data are recorded in a non-volatile memory. Such data include electronic name-plate, operating cycles, running times, error memory and information for predictive maintenance.

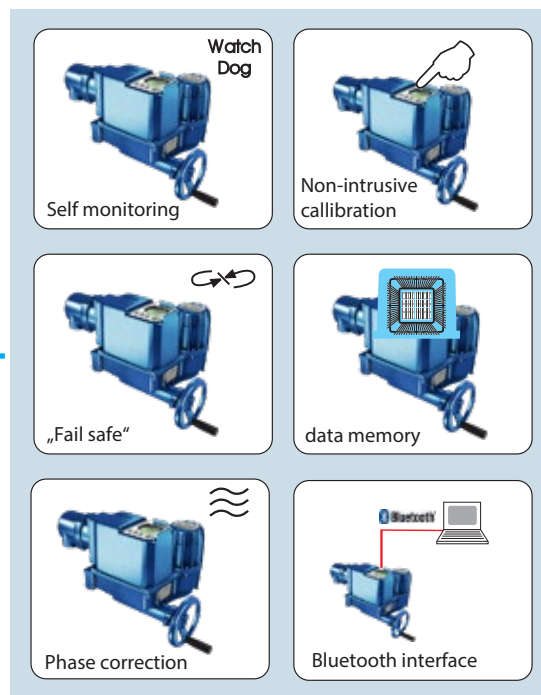

PHASE SEQUENCE CORRECTION/ SINGLE-PHASE MONITORING

This module ensures that the actuator produces the correct direction of rotation for opening and closing the valve, regardless of the sequence in which the three-phase network phases are applied. Whether the closing direction is to the right or left is defined by remote or local parameterization. Additionally all phases will be monitored. At phase failure a corresponding error message is generated.

BLUETHOOH INTERFACE

Each i-matic actuator is equipped with a bluetooth interface. On this way all data (diagnostic files) can be read out, parameters can be set and firmware can be downloaded. With the software tool "i-matic Explorer", operating and setting tasks are made easily.

VALVE / POSITION-TORQUE-CURVE

The actuator comprises a function for displaying and recording the torque curve. The curves for plant commissioning on the valve and for cold and warm plant commissioning can be permanently stored in the actuator. Torque curves can be used for a demand oriented maintenance of valves.

POSITIONER

Modulating actuators are directly controlled by a higher level process controller (e.g. pressure, temperature, flow rate) via a 4-20 mA setpoint value. The integrated positioner compares the reference signal (setpoint value) with the analogue position signal generated by the actuator (actual position value) and generate corresponding driving commands. With driving the actuator the modulating behaviour parameters can be set the sensitivity of the actuator to optimally adjusting the modulating actuator to the control process.

SIGNAL MEMORY

In case of loss of main power supply feedback signals can remain at the current status with the following options:

- > 24 V DC external supply of control voltage or
- > battery pack (automatic rechargeable) or
- > remanence relays

REMOTE PARAMETERIZATION

While the plant is in operation, all settings can be remotely parameterized and permanently overwritten via the bus using the central parameterization and visualizing tool. The original setting can be retrieved with a reset command.

You can use:

- > i-matic-Explorer
- > SiMATIC PDM
- > FDT/DTM as a visualization software.

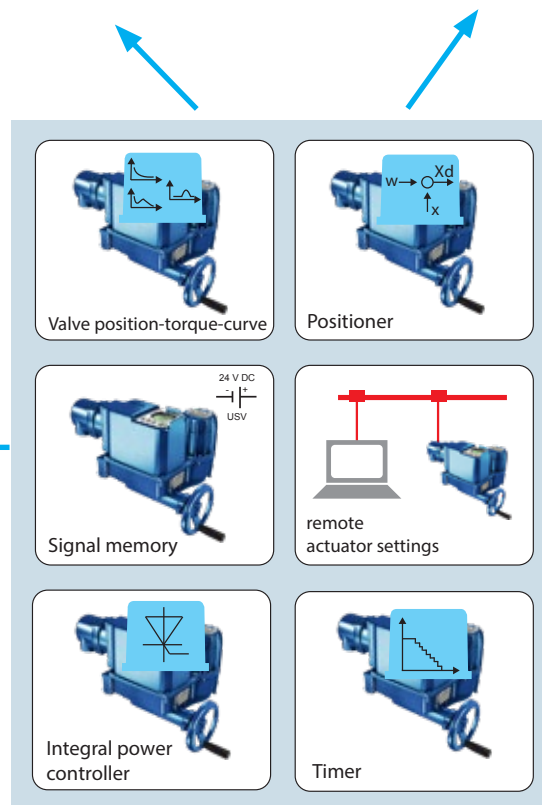

POWER UNIT

Electrically and mechanically interlocked reversing interlocked reversing contactors are used. For modulating duty solid state relays are available as an option.

TIMER

The timer can extend the actuating time over the entire stroke or over a user-definable partial section up to the limit position. The timer operation in opening or closing direction can be parameterized. A further parameter determines whether the range for timer operation is specified using an internal setting or using an optional binary input on the interface for remote commands. Three values are applied for parameterizing the timer operation.

- > Pulse time t_{on} (0.5 s to 30 s)
- > Pulse time t_{off} (0.5 s to 30 s)
- > Start of timer (0 % to 100 % actuator travel)

Data and parameters

ELECTRONIC NAMEPLATE

All important MOV relevant information can be found inside the electronic nameplate. The according data are:

- > Bluetooth identification
- > Information about the on-site installation, e.g. TAG/KKS-ID
- > Actuator nameplate, e.g. torque range, type of duty, ...
- > Control unit details, e.g. serial number, wiring diagram, ...
- > Motor nameplate, e.g. power requirements, motor type, ...
- > Gear/thrust unit information, e.g. gear ratio, factor, ...
- > Valve information, e.g. torque range, type, manufacturer, ...

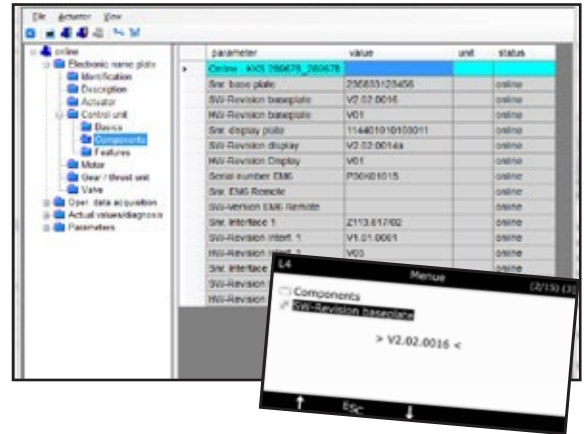

OPERATING DATA

Operating data are continuously logged and evaluated.

- > General e.g. calibration date, configuration date, ...
- > Operation data, e.g. motor operating time, operation cycles, ...
- > Dynamic maintenance, e.g. mechanical ageing, ...
- > Faults, e.g. number of torque warnings, thermal overloads, ...
- > System data, e.g. up time electronic, number of power-on, ...

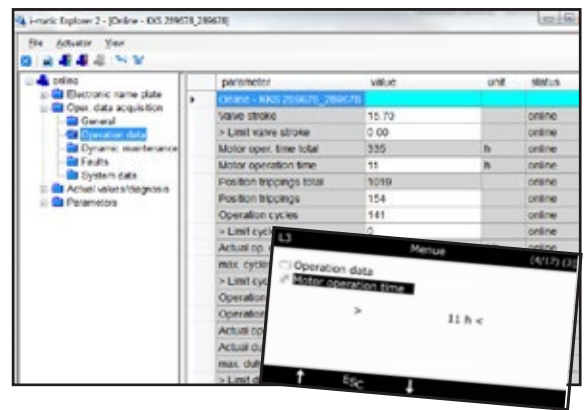

ACTUAL VALUES/DIAGNOSIS

Various parameters are available for maintenance and diagnostic purposes.

- > Error stack, contains a list of occurring faults
- > Process data, e.g. operation mode, actual and setpoint position, ...
- > Power supply, e.g. phase sequence, 24V internal status, ...
- > System, e.g. electronic and sensor temperature, ...
- > Interface, e.g. fieldbus and I/O board diagnosis information, ...
- > Battery Backup, e.g. status and temperature of battery

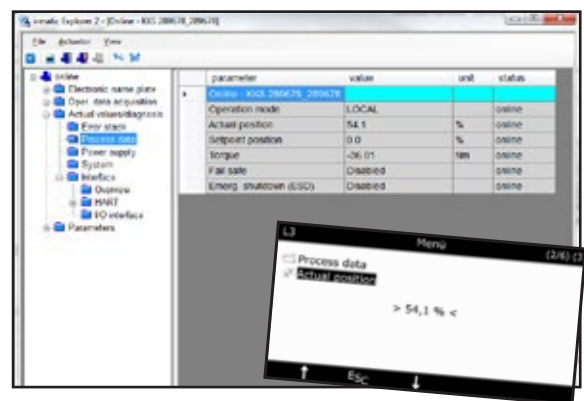

PARAMETER

Suitable parameters are available for commissioning and configuration.

- > Power supply, e.g. phase correction and monitoring
- > Display unit, e.g. language, date, time, LED colour, ...
- > Data logging, e.g. torque and position unit, ...
- > Valve, e.g. settings, intermediate positions, monitoring, ...
- > Actuator, e.g. thermal failure delay, ...
- > DCS/PLC system, e.g. ESD, fail safe, collective failure, interface, ...
- > Process, e.g. modulating behaviour of internal positioner, ...

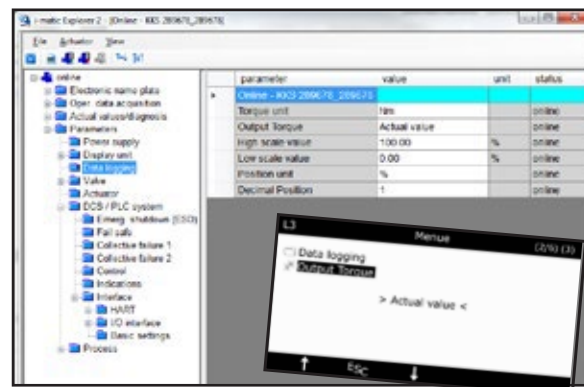

TORQUE LINE CHART

Beside the opportunity to store up to four different torque curves, it is possible to visualize the current torque values on a progress line chart.

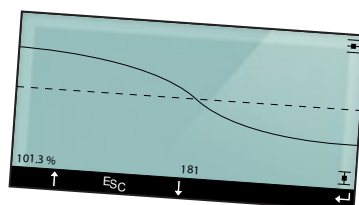

Configuration and diagnostic tools

TOOLS

For configuration and diagnostics of i-matic actuators the tool i-matic Explorer is offered. The i-matic Explorer is available as a desktop variant and for mobile devices (i-matic Explorer Mobile) such as smartphones and tablets. Unauthorised online access to the actuator is protected by means of bluetooth password protection and user access levels. The i-matic Explorer supports the following features:

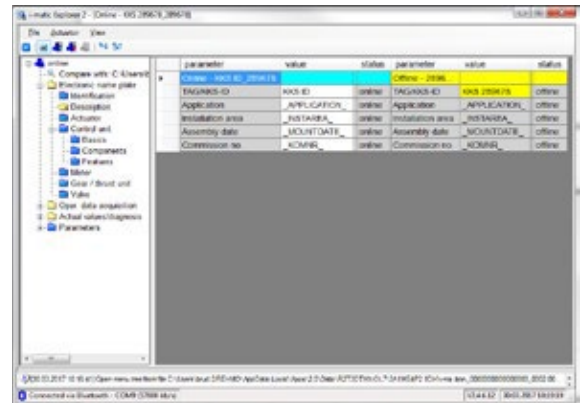

PARAMETER EXPLORER

An identical representation of the actuator menu tree is accessible in a comfortable way. The parameter Explorer enables the configuration and diagnosis of i-matic actuators. For later analysis the parameter sets can be saved and compared with current values.

TORQUE CURVES EXPLORER

This dialog visualizes the torque values at different valve positions read out from the actuator as a torque curve. Torque curves can be stored, compared and analyzed. In this way degradations and problems of the valves can be determined.

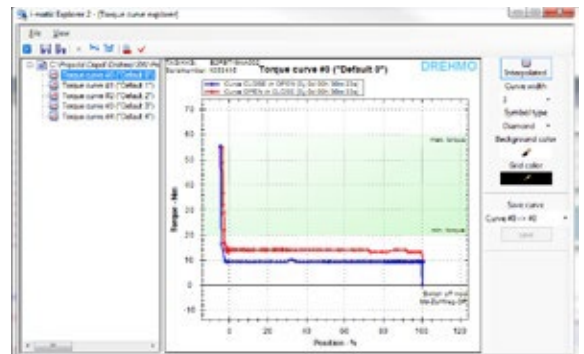

VIRTUAL CONTROL STATION

Manual operation of the actuator via a Virtual Control Station is possible. This allows access of hard to reach actuators.

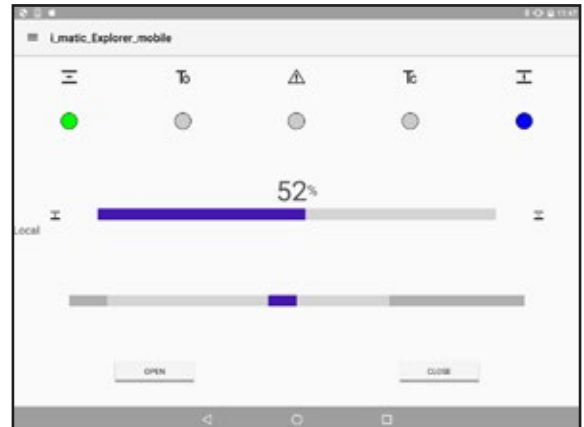

FIRMWARE UPDATE MANAGER

A dialog-controlled firmware update makes it very easy to integrate new functions without expertise.

DCS/PLC INTERFACE EVALUATION

Analog and digital feedbacks can be simulated. Analog and digital commands from DCS/PLC are visualized. With these signals the connection between DCS/PLC and the actuator can be evaluated during commissioning and maintenance.

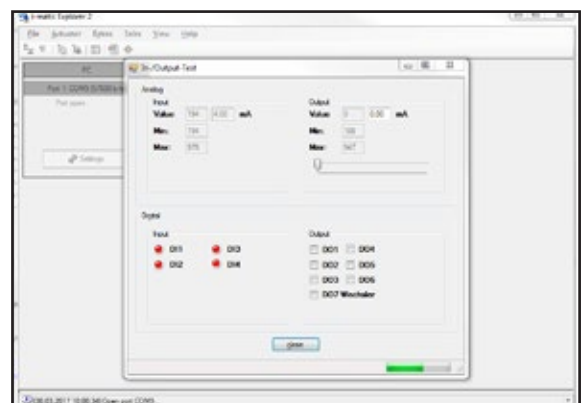

Electrical connection

The plug-in electrical connector is a key element of the modular actuator design. The connector is a separate unit. The different connection types are compatible throughout all type ranges and can be used for actuators with or without integral controls.

During maintenance work, the wiring remains undisturbed; electrical connections can be quickly separated and reconnected. This reduces downtimes and avoids wiring faults when reconnecting.

1 Plug/socket connector

The 50 contact plug/socket connector is the core element for all connection types. Incorrect connection is prevented by special code pins. Power cable 2,5 ... 6,0 mm², Control cable 0,75 ... 2,5 mm²

2 Cover for electrical connection S

With three cable entries. Basic version: 1 x M20 x 1,5, 1 x M25 x 1,5, 1 x M32 x 1,5

3 Cover for electrical connection SH

With additional cable entries, offers 75 % more space than standard version.

4 Intermediate frame DS for double sealing

Preserves the enclosure protection even if the electrical connection is removed and prevents ingress of dirt or humidity into the housing. Can be combined with any electrical connection type and is easily retrofitted.



FIELDBUS CONNECTION

If communication via parallel signal transmission is required, the i-matic is equipped with one of the electrical connections as described above. When using fieldbus technology, special connections are used. They are based on the plug-in design just like the other connectors.

5 Fieldbus connection SD

A connection board for easy connection of fieldbus cables is integrated. Fieldbus communication is not interrupted even when connector is removed. Connection is made via fieldbus specific characteristics. For example for Profibus as shown, termination resistors are integrated.

6 Fieldbus connection SDE with FO couplers

For direct connection of fibre optic cables to i-matic controls. Comparable in design to SD connection but with larger diameter to comfortably accommodate the specified FO cable bending radii. The FO module contains diagnostic functions to monitor fibre optic cable quality.

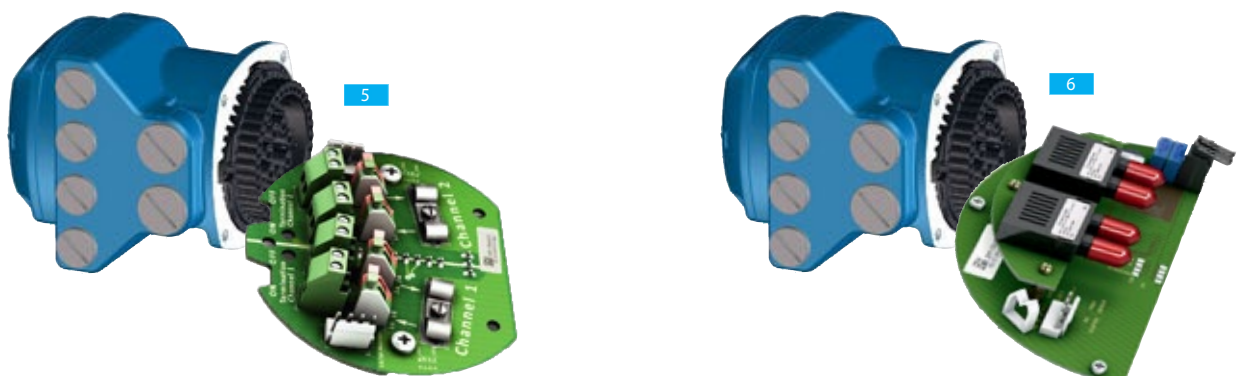

Additional Equipment

DETACHED I-MATIC CONTROL UNIT/ DETACHED LOCAL CONTROL STATION

If the actuator is difficult to access or in case of extreme vibration or high ambient temperatures at the place of valve installation, controls with operating elements can be mounted separately from the actuator on a wall bracket.

- 1 Wall bracket**
The actuator control is mounted on a separate wall bracket and fulfills protection class IP 68.
- 2 Detached i-matic control unit**
The actuator control unit is separated.
- 3 Actuator housing**
A special housing is used to cover the sensor area.
- 4 Electric connection**
Electric connection is done by a plug/socket connector.
- 5 Interconnection**
The interconnection consists of two lines, power and data.
The cable length between actuator and controls may be up to 100 m.

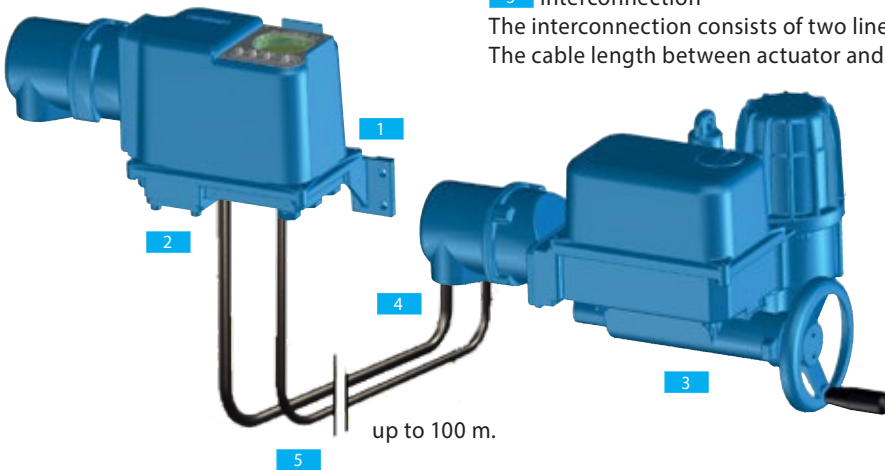

SUN SHADES

In order to protect the electronic unit from heating up by high intense sun light, sunshades are available as option.

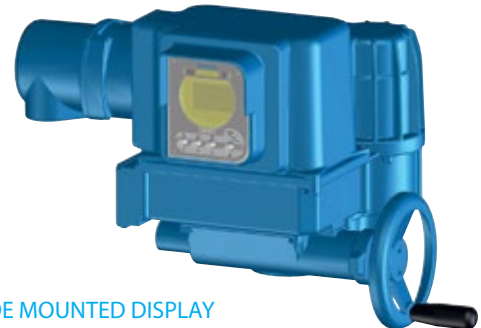

SIDE MOUNTED DISPLAY

The electronic housing is also available in a special-side mounted display-design

PROTECTION AGAINST UNAUTHORISED ACCESS AT LOCAL CONTROLS

Following solutions are available:

- > Password protection: Different user-levels can be used for protection against local operation or settings.
- > Padlock protection (option): The push button for operational mode (REMOTE-OFF-LOCAL-LEARN) can be locked with a commercially available padlock. Thus locked, the operating mode cannot be changed.
- > Magnetic pen operation (option):
Instead of the push buttons the operation can be done with a special magnetic pen. Operation is only possible with this special magnetic pen.
- > Lockable protection cover (option): The lockable protection cover offers increased protection, even against damage to the local controls.
- > Remote release of the local controls (option): Remote release ensures optimum protection against unauthorised operation. The local controls can only be operated after a release signal from the higher level controls.

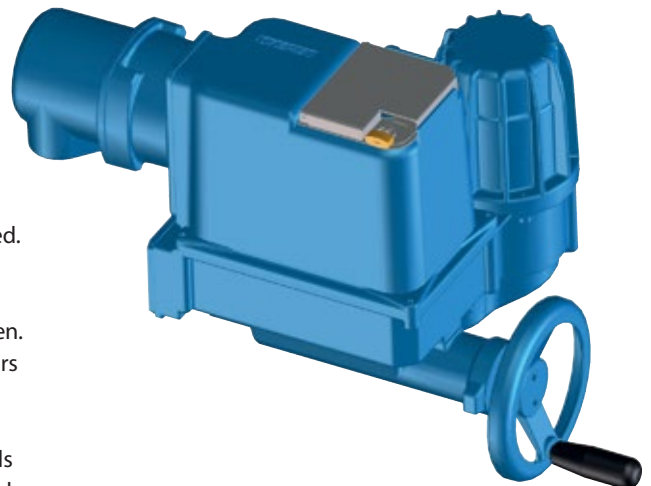



CLEARLY STRUCTURED OPERATION

For the i-matic, accessing the considerably more detailed data is facilitated by a clearly structured and intuitive user interface.

All device settings can be performed without requiring any additional parameterisation tool. The display structure is user-friendly, in plain text and available in a large number of languages.

- 1 Display**
The graphic display shows texts and graphic elements as well as torque curves
- 2 Indication lights**
Visual status signals via indication lights can be programmed. Signals indicated via LEDs are clearly visible even from longer distances
- 3 Multifunctional push buttons**
Operation by means of four conventional push buttons or optionally by use of a magnetic pen
- 4 Bluetooth Interface**
Data exchange between the actuator and the i-matic Explorer

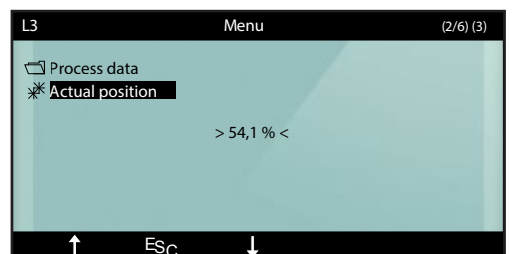
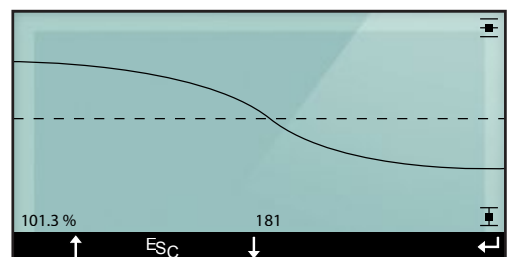
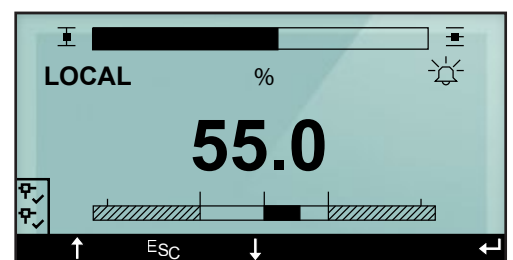

TAILOR-MADE INTERFACES

The mechanical interface to the valve is standardised. On the other hand the interfaces between the control station and operator are constantly evolving.

Parallel control, fieldbus, or both for reasons of redundancy?
When fieldbus, which protocol to use?

Irrespective of your decision on the interface, DREHMO actuators can be equipped with the suitable interface to match all systems established within process control engineering.

ACTUATOR COMMANDS AND FEEDBACK SIGNALS

In simple applications, operation commands OPEN and CLOSE, feedback signals, End position limit OPEN/End position limit CLOSED reached as well as Collective fault signal suffice. Any isolating valve can be reliably operated with these five discrete signals.

However, if the valve position is to be controlled, further continuous signals are required: Position setpoint and Position feedback signal (actual value), typically a 4 – 20 mA analogue signal for parallel communication.

Fieldbus protocols expand the bandwidth for information transmission. Further to transmission of commands and feedback signals required for operation, access to all device parameters and operating data via fieldbus from the control station is made available.

I-MATIC

Signal assignment of the outputs can be modified later via i-matic device setting. Depending on the version, it provides:

- > Up to four digital inputs e.g. operation commands OPEN, STOP, CLOSE, release signals for local controls, EMERGENCY commands, etc.
- > Up to seven digital outputs e.g. for feedback of end positions, intermediate positions, selector switch position, failures, etc.
- > One analogue input (4 – 20 mA) e.g. for setpoint reception to control the positioner
- > One analogue output (4 – 20 mA) e.g. for feedback of valve position or torque

The digital inputs and outputs are potential-free. Optional the analogue signals are galvanically isolated available.

BISTABLE INTERFACE

At power failure the relay contacts of this add on board maintain their condition.

This board is an optional station I/O interface which expands the i-matic in addition with:

- > 6 digital inputs (115VAC or 24V DC)
- > 6 digital outputs (4 digital outputs with bistable signaling relay)



Fieldbus communication

DREHMO FIELDBUS DEVICES

Many different fieldbus systems are available on the market. Certain preferences have evolved on a regional level or specific to certain plant applications. Since DREHMO actuators are implemented in all types of technical process plants around the globe, they are available with any communication system established in this industry.

- > Profibus DP
- > Modbus RTU
- > Foundation Fieldbus
- > HART

DREHMO devices are available with digital and analogue inputs to connect additional sensors to the fieldbus as optional.

PROFIBUS

Profibus offers a complete family of fieldbus versions: Profibus PA for process automation, Profinet for data transmission based on Ethernet and Profibus DP for automating plants, power plants and machines. Due to its simple and robust physical layer (RS-485) and the different service levels DP-V0 (fast cyclic and deterministic data exchange), DP-V1 (acyclic access to device parameters and diagnostic data) as well as DP-V2 (further functions such as time stamp or redundancy), Profibus DP is the ideal solution for plant automation.

International standard, IEC 61158/61784 (www.profibus.com)

- > Large installation base
- > Standardised integration within the DCS
- > Large selection of devices (FDT, EDD)
- > Worldwide distribution

Drehmo actuator with Profibus DP

- > Support Profibus DP-V0, DP-V1 and DP-V2
- > High speed data exchange (up to 1.2 Mbit/s)
- > Integration within the DCS via EDD or FDT
- > Cable length up to approx. 10 km (without repeater up to 1.200 m)
- > Up to 126 devices can be connected
- > Option: Redundant line topology or master slave redundant
- > Option: Data transmission via fibre optic cables (Option: over voltage protection up to 4 kV)

PROFIBUS

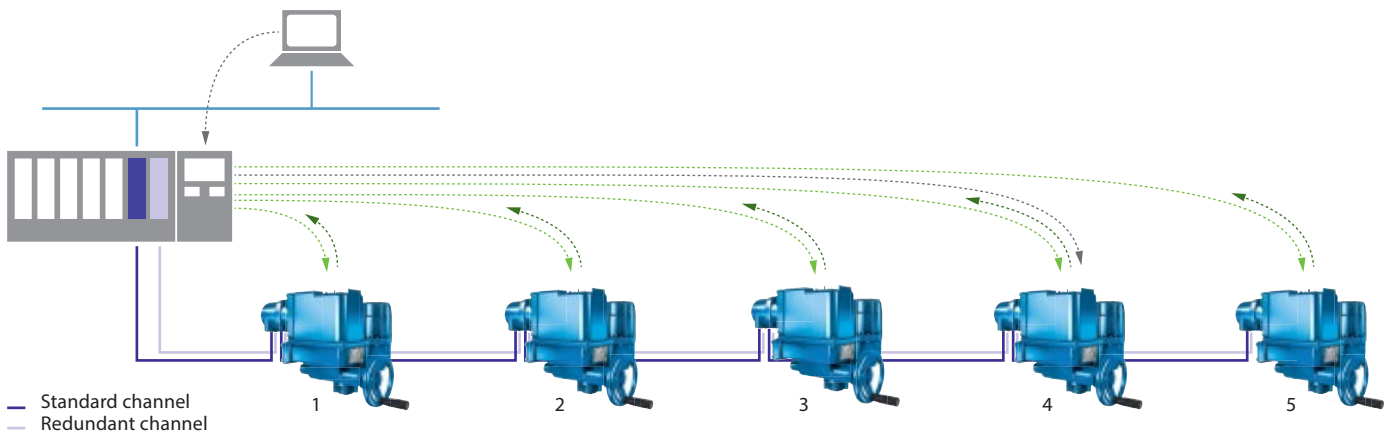

Bus cycle with 5 actuators

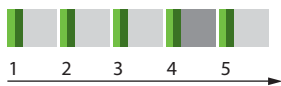

- Cyclic process data request from master
- Cyclic process data feedback from slave
- Acyclic diagnostics or parameter data transmission

MODBUS

In comparison with other fieldbus technologies, Modbus is simple but has a multi-functional fieldbus protocol. It offers all functions required for plant automation, e.g. exchange of simple, binary information, analogue values, device parameters or diagnostic data.

For plant automation and similar to Profibus, the simple and robust physical layer RS-485 is often used.

On the basis of this physical layer, Modbus supports various telegram formats, e.g. Modbus RTU or Modbus ASCII. Using the Modbus TCP/IP version based on Ethernet, vertical integration into a host automation system is often implemented.

- > International standard, IEC 61158/61784, www.modbus.org
- > Simple protocol
- > Worldwide distribution
- > Largely sufficient for many simple automation tasks

DREHMO actuators with Modbus RTU

- > Fast data exchange (up to 115.2 kbit/s)
- > Cable length up to approx. 10 km (without repeater up to 1.200 m)
- > Up to 247 devices can be connected
- > Option: Redundant line topology
- > Option: Redundant loop topology
- > Option: Data transmission via fibre optic cables
- > Option: Overvoltage protection up to 4 kV

DREHMO actuators with Modbus TCP/IP

- > Modbus TCP/IP is available by means of a Modbus RTU gateway inside the plug-in electrical connector
- > data exchange 10/100 Mbit/s
- > Field-mountable RJ-45 connector (Cat. 6A)

Modbus

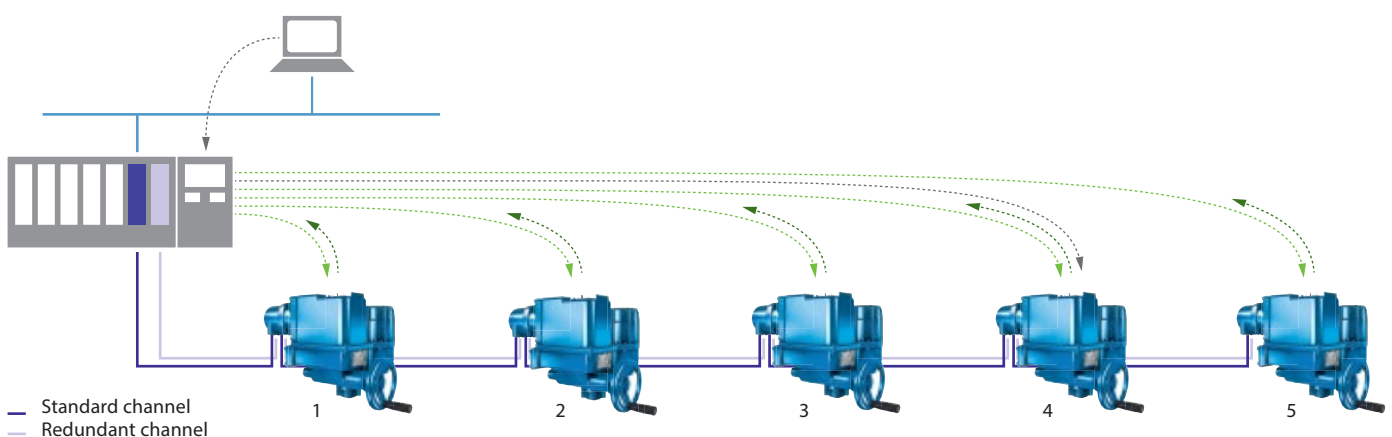

Bus cycle with 5 actuators



FOUNDATION FIELDBUS

Foundation Fieldbus (FF) was explicitly adapted to the requirements of process automation. The distributed data transmission within the Foundation Fieldbus network enables field devices perform automation tasks. Decentralization of automation to the field level relieves the central process control. Transmission physics of the FF H1 protocol used at field level are based on IEC 61158-2 and ISA SP 50.02. These standards define the framework for data transmission and energy supply of field devices using the same cable pair. FF H1 supports various topologies. In combination with junction boxes or segment barriers, various wiring structures are possible. Apart from conventional line and tree structures, FF H1 supports point-to-point topology or other structures with one trunk combined or individual spurs leading to the field devices.

Foundation Fieldbus data interfaces are based on standardised function blocks, for example AI (Analog Input), or AO (Analog Output) whereby their inputs and outputs can be linked. Therefore, FF fieldbus devices can directly communicate with each other provided that the segment is equipped with a Link Active Scheduler (LAS) to coordinate FF communication.

DREHMO ACTUATORS AND FOUNDATION FIELDBUS
DREHMO i-matic support FF H1 version.

- > Data exchange at 31.25 kbit/s, typical macro cycle 1 s
- > Cable length up to approx. 9.5 km (without repeater up to 1.900 m)
- > Up to 240 devices can be addressed, typically 6 to 15 field devices are available
- > Integration within the DCS via EDD or DTM
- > DREHMO actuators support LAS and thus adopt the tasks of the link active scheduler.
- > Option: Overvoltage protection up to 4 kV
- > Option: FISCO connection
- > International standardised, IEC 61158-2/SASP50.02, www.fiedlbus.org
- > Worldwide distribution

FOUNDATION FIELDBUS



HART

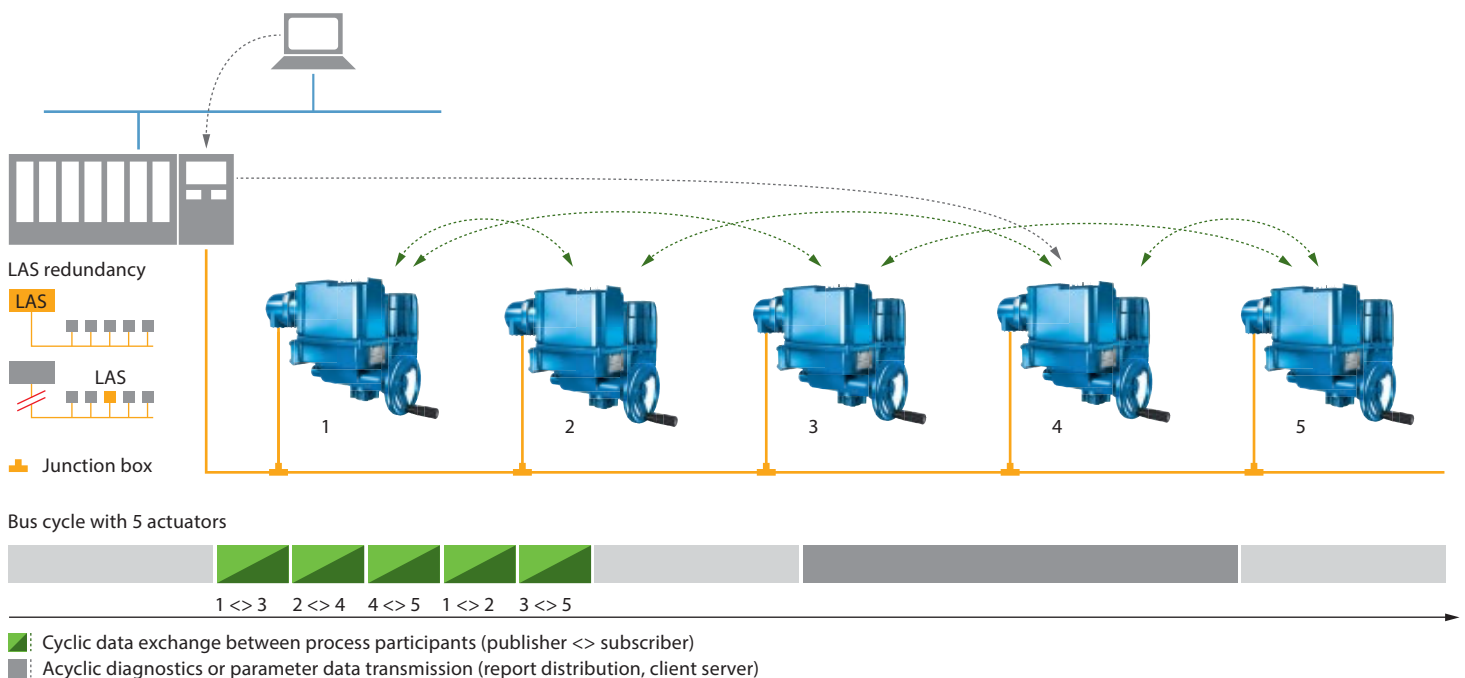

HART

HART makes use of the known 4 – 20 mA standard signal for analogue data transmission. HART communication is modulated as additional signal to the analogue signal. Advantages: Simultaneous transmission of digital HART information to the analogue signal. Bidirectional transmission of HART information. No termination or line screen required. Wiring test with multimeter. Existing 4 – 20 mA infrastructure is also available for digital communication. Facilitates reading additional parameters and diagnostic data from field devices. HART uses the master-slave principle and offers various commands for data transmission. Normally, the conventional point-to-point topology is used.

- > International standard, IEC 61158/61784 (CPF9)
- > Worldwide distribution
- > Large installation base
- > Standardised integration within the DCS (FDT, EDD)
- > Large selection of devices

DREHMO ACTUATORS WITH HART

- > Support of 2 device categories
 - 1 ACTUATOR:
 - HART signal based on analogue setpoint from DCS
 - 2 CURRENT OUTPUT:
 - HART signal based on analogue actual position from actuator
- > Transmission of parameter and diagnostic data via digital HART communication
- > Data exchange at 1,2 kBits (Bell 202, telephone std.)
- > Integration within the DCS via EDD or FDT/DTM
- > Length of cable approx. 3 km

DREHMO ACTUATORS WITH WIRELESS HART

- > Device categorie CURRENT OUTPUT
- > with wireless-adapter mounted inside special plug connector frame
- > Option: separation of wireless-adapter for any mounting position

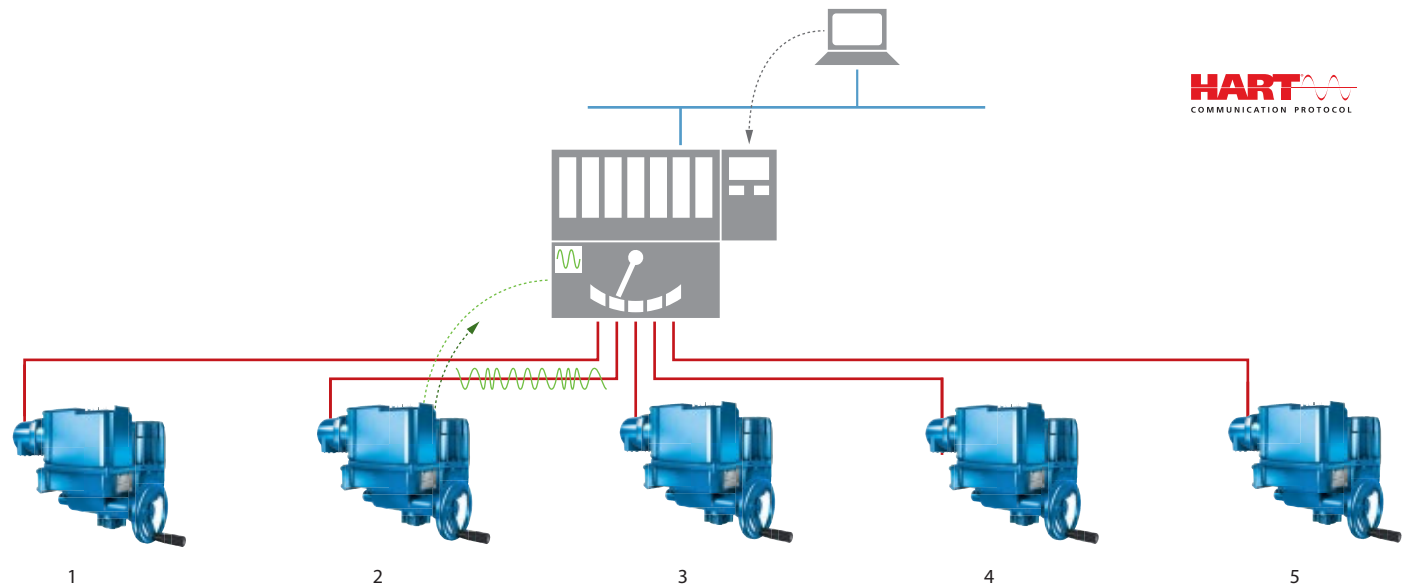

HART
COMMUNICATION PROTOCOL

— Conventional 4 – 20 mA signal cable
 ~ Digital HART communication

Cycle with 5 actuators



— Parameter or diagnostic data request from master
 — Parameter or diagnostic feedback from slave
 — Analogue process signal

CENTRAL FIELD DEVICE MANAGEMENT

EDD and FDT/DTM are two independent technologies for harmonisation of device integration within fieldbus systems across all field devices. This includes for example device configuration, device replacement, fault analysis, device diagnostics, or documentation of these actions. For this reason, EDD and FDT are crucial for Plant Asset Management and Life Cycle Management of a plant.

Besides the imperative main functions, field devices possess diagnostic functions and many specialised application functions to adapt the device to the process and environmental conditions as required. If certain prerequisites are fulfilled, for Profibus e.g. the DP-V1 protocol, data exchange connected to these functions can directly take place between control station and field device. For DREHMO actuators, this further includes status and diagnostic signals in compliance (according to NAMUR NE 107 only at Foundation Fieldbus & HART), parameter modifications of user functions, information of the electronic device ID or operational data for preventive maintenance. EDD or FDT is used to harmonise access from the control station to the data available with the various field devices.

EDD

Each field device supporting this technology is provided with an EDD (Electronic Device Description). This file combines device parameters described in ASCII using standardised and platform neutral EDD language. This technology helps to create a uniform user philosophy with identical parameter visualisation across all field devices.

FDT/DTM

FDT (Field Device Tool) is a software interface definition to integrate DTM (Device Type Manager) into the FDT system of the maintenance processor. DTM is a software module supplied by field device manufacturers. Similar to a printer driver, DTM is installed within the FDT frame application to visualise settings and information available from the field devices.

DTMs are available on request. EDDs for DREHMO actuators can be downloaded at: www.drehmo.com

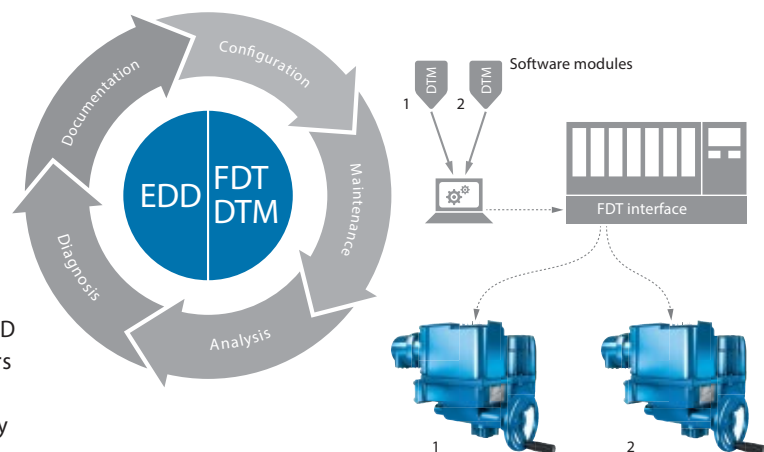

DATA TRANSMISSION VIA FIBRE OPTIC CABLE

Long distances between the devices combined with the high demands for data transmission security - in this instance, fibre optic cables are a suited transmission medium.

Long distances

Low attenuation of light signals in fibre optic cables allows coverage of long distances between participants, resulting in a considerably higher total fieldbus system length. With multi-mode cables, distances up to 2.6 km between devices can be achieved.

Integral overvoltage protection

Contrary to copper cables, fibre optic cables are resistant to electromagnetic interference. Separated installation of signal cables and power cables is no longer required. Fibre optic cables provide galvanic isolation between actuators. This offers particular protection against overvoltages, for example in the event of lightning.

DREHMO actuators with fibre optic interface (FO)

FO module for converting actuator-internal electrical signals into fibre optic signals is integrated within the electrical connection of the actuator. Connection of fibre optic cables is made via conventional FSMA plug/socket connectors.

When using Profibus DP, line, star and ring topology are possible. In this case, the availability of the fibre optic ring is monitored. If the ring is interrupted, a warning will be sent. This warning is integrated within the signalling pattern of i-matic actuator controls, visualised on the display and transmitted to the control station in compliance with the specified signalling pattern.

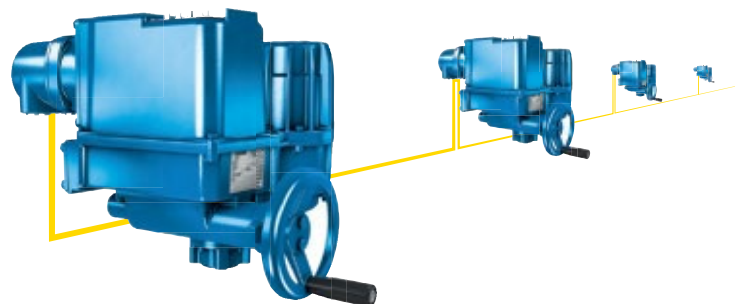

Comparison of max. distances between bus participants

Copper cable	1.2 km
FO multi-mode	2,6km
FO single-mode	15 km

SIMA² - THE FIELDBUS SYSTEM SOLUTION

SIMA² MASTERSTATION

SIMA² is the ideal master station for perfect integration of actuators into a DCS. Entire communication is based on open fieldbus protocols.

- > SIMA² supports the user with a mostly automated procedure for commissioning the connected actuator network, irrespective of the DCS - plug and play.
- > SIMA² manages and monitors communication to field devices including all redundant data channels and hot standby components.
- > SIMA² as data concentrator collects all actuator status signals and sends the signals relevant for normal service to the DCS.
- > SIMA² facilitates status information access to the connected actuators.
- > In the event of failures, SIMA² supports fast fault identification and remedy.
- > SIMA² serves the purpose of gateway to adapt fieldbus communication with actuators to the available interfaces of the DCS

> Configuration interface

SIMA² can be operated from your favourite end device: Either directly via the integral 7" multi-touchscreen or remotely via PC, laptop, tablet or smartphone. Thanks to the integral web server, the same comfortable user interface is available for both the touchscreen and also the standard web browser. SIMA² Master Station diagnostic representation is based on the diagnostic classification and icons by NAMUR NE 107. Settings and configurations are password protected for different user levels.

> SIMA² Master Station

SIMA² Master Station uses state-of-the-art hardware and software design. The entire hardware is housed in a robust 19" rack-mount enclosure.

> Hot Standby SIMA²

Increased availability and reliability can be achieved by installing a backup SIMA², taking over all tasks of the primary SIMA² in case of failure. This Hot Standby SIMA² can be integrated in the same enclosure to minimize installation space.

> Redundant Modbus loop

The major advantage of this topology is the integrated redundancy. If the loop is interrupted, SIMA² considers both segments as separate lines and all actuators remain accessible. Actuators selected for this topology are equipped with a repeater function for galvanic isolation of loop segments and for Modbus signal amplification.

> Redundant line topology with Modbus RTU or Profibus DP

The connection from SIMA² Master Station to the field devices is made on two channels; this means that two separate fieldbus cables are installed for each actuator. Failure of one of the communication channels initiates immediate change-over to the second channel.

> Fieldbus Networks per SIMA² Master Station

A single SIMA² Master Station can manage up to four independent, galvanically isolated and logically separated actuator networks. Altogether 247 network participants can be controlled per network – a total of up to 988 actuators per SIMA² Master Station. Maximum cable length up to 296 km.

> DREHMO actuators

DREHMO actuators are equipped with the suitable interface matching selected fieldbus protocol and topology. Individual devices can be separated from the fieldbus without interrupting fieldbus communication to other devices.

> Communication with DCS

DCS communication is possible using Modbus RTU (redundant), OPC UA or Modbus TCP/IP (redundant).



- DREHMO actuators, other actuators, sensors etc. in line or loop topology

Advantages

- > reduction of the data volume to the DCS
- > central level for control and diagnostic
- > simple maintenance for network loops
- > additional operating function
- > for complete diagnostic of the entire actuator network and simple DCS integration

Technical data

MULTI-TURN ACTUATOR DiM



Actuator Model	Actuator speed [rpm]	Torque Adjustment Range [Nm]	Connection Flange According to DIN EN ISO 5210 (standard)	Connection Flange According to DIN EN ISO 5210 (special request)	Connection Flange According to DIN 3210 (special request)	Max. allowable spindle diameter at form A ¹⁾ [mm]	Max. allowable axial force at form "A" [kN]	Type of Duty S2-... min
DiM 30	5,10,16, 25,32,40, 50,80 120 ^{1),2)} ,160 ^{1),2)}	10-30	F07 -	- F10	- G0	24 28	30 40	10/15 ⁶⁾
DiM 59		20-60	- F10	F07 -	- G0	24 28	30 40	10/15 ⁶⁾
DiM 60		20-60	- F10 -	F07 - F14	- G0 G1/2	32 40 40	60 60 60	15
DiM 120		40-120	F10 -	- F14	G0 G1/2	40 40	60 60	15
DiM 249		80-250	- F14	F10 -	G0 G1/2	40 40	60 60	10/15 ⁶⁾
DiM 250		80-250	F14	F16	G1/2	52	120	10/15 ⁶⁾
DiM 500		5,10,16, 25, 32, 40, 50, 80,120 ^{1),160¹⁾, 200⁴⁾}	150-500	F14	F16	G1/2	52	160
DiM 1000	5,10,16, 25, 32, 40, 50, 80,120 ^{1),4)} ,160 ^{1),4)}	300-1000	F16	-	G3	65	190	10
	200 ⁴⁾	300-800						
DiM 2000 ⁴⁾	20,40,80,120, 160, 200	800-2000	F25	⁵⁾	⁵⁾	80	380	15

¹⁾ Actuators with this speed are not self-locking

²⁾ Not available for sizes D... 249

³⁾ For form B, B1, B2, C dimension d5 to be observed

⁴⁾ Special safety provisions have to be implemented for pulling loads

⁵⁾ on request

⁶⁾ Type of duty S2 -... min., depending on actuator speed, more details on page 26 (motor data)



Technical data

MULTI-TURN ACTUATOR FOR MODULATING DUTY DIM R



Actuator Model	Actuator Speed [rpm]	Required min. Length of Signal for Operating into Same Direction [ms ³⁾	Hysteresis [ms]	Torque Adjustment Range [Nm]	Max. Modulating Torque [Nm]	Connection Flange to DIN EN ISO 5210 (Standard)	Connection Flange to DIN EN ISO 5210 (Special Request)	Connection Flange to DIN 3210 (Special Request)	Max. Allowable Stem Diameter Output Drive A ¹⁾ [mm]	Max. Allowable Axial Force Output Drive "A" [kN]
DIM R 30	5	65	290	15-30	15	F07	-	-	24	30
	10	65	84							
	16	65	53							
	25	65	34							
	32	65	26							
	40	65	22							
DIM R 59	5	65	290	30-60	30	F10	-	G0	28	40
	10	65	84							
	16	65	53							
	25	65	34							
	32	65	26							
	40	65	22							
DIM R 60	5	65	400	30-60	30	F10	-	G0	40	60
	10	65	200							
	16	65	122							
	25	65	48							
	32	65	39							
	40	65	31							
DIM R 120	5	65	127	60-120	60	F10	-	G0	40	60
	10	65	64							
	16	65	39							
	25	65	48							
	32	65	39							
	40	65	31							
DIM R 250	5	65	127	120-250	120	F14	F16	G1/2	52	120
	10	65	64							
	16	65	39							
	25	65	25							
	32	65	21							
	40	65	16							
DIM R 500	5	65	127	200-500	200	F14	F16	G1/2	52	160
	10	65	64							
	16	65	39							
	25	65	25							
	32	65	21							
	40	65	16							
DIM R 1000 ²⁾	5	65	117	500-1000	500	F16	-	G3	65	190
	10	65	66							
	16	65	4 ⁴⁾							
	25	65	4 ⁴⁾							

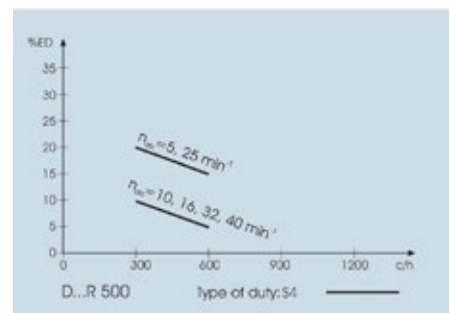
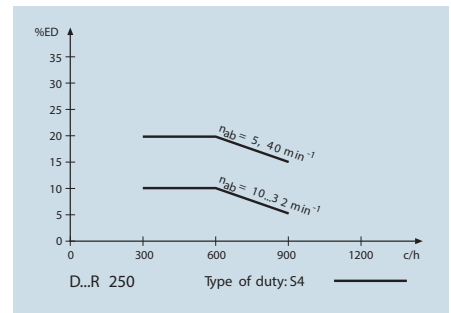
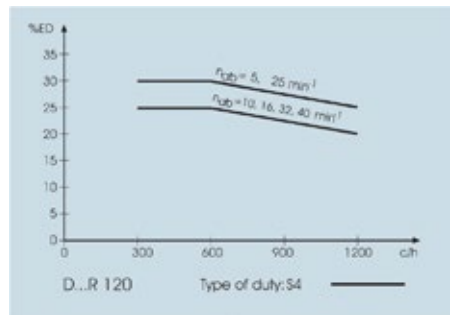
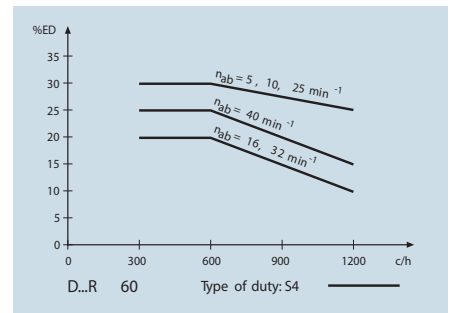
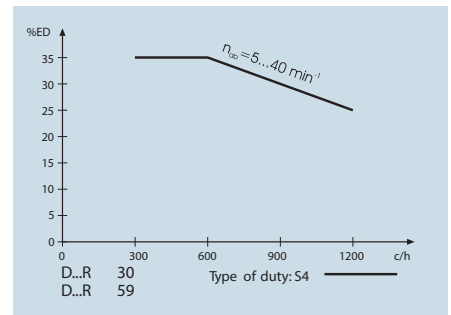

- 1) For model B, B1, B2, C please consider dimension d5
- 2) Max. duty cycle 10 % max. operations per hour 300 (c/h)
- 3) Without consideration of signal running times caused by control processes
- 4) On request

Percentage of operation (% ED) within one hour in relation to number of duty cycles (c/h) per hour for different actuator output speeds (n_{ab}) at a temperature of max. 60 °C.

Actuator Dimensions

MULTI-TURN ACTUATOR DiM

MULTI-TURN ACTUATOR FOR MODULATING DUTY DiMR



Actuator Models DiM, DiMR	30	59	60	120	249	250	500	1000	2000	
Weight [kg]	23	25	33,5	33,5	33,5	69,5	80,5	90,5	190	
Dimensions [mm]										
L max.	561	561	596	601	601	661	732	732	811	
T4 max.	287	287	334	360	360	455	530	580	757	
H max.	344	344	357	402	402	570	695	745	934	
D1	Ø160	Ø160	Ø160	Ø250	Ø250	Ø250	Ø400	Ø500	Ø500	
D2 max.	Ø127	Ø127	Ø160	Ø160	Ø160	Ø245	Ø245	Ø245	Ø245	
H1a	280	280	331	331	331	492	542	542	730	
H1b	313	313	331	331	331	404	404	404	471	
H2	238	238	256	256	256	306	306	306	373	
H4	49	49	55	55	55	69	69	69	125	
H5	140	140	160	160	160	210	210	210	169	
H6	250	250	270	270	270	452	452	452	500	
	352	352	372	372	372	702	702	702	-	
	452	452	472	472	472	952	952	952	-	
	552	552	572	572	572	-	-	-	-	
	652	652	672	672	672	-	-	-	-	
L2	209	209	244	232	232	264	311	311	348	
L3	499	499	533	521	521	581	628	628	706	
L5	63	63	63	80	80	80	105	105	105	
T1	102	102	112	112	112	128	128	128	205	
T2	179	179	205	205	205	214	214	214	294	
T3	178	178	187	232	232	260	335	385	450	
T4a	287	287	334	334	334	412	412	412	601	
IM-unit	2)					408 x 153 x 163 (L x T x H)				420 x 170 x 185 (L x T x H)

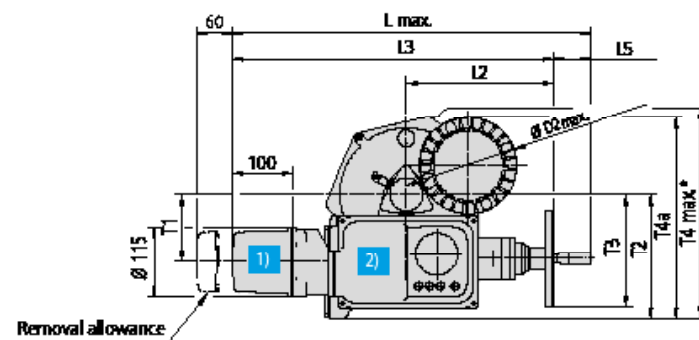
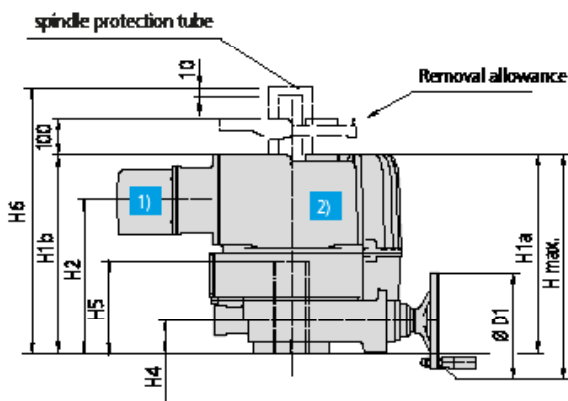

1) Cover for electrical connection S refer to page 12. Options available.

2) Electronic unit (IM-unit) coversize including cover for electrical connection

* Depending on the device, the outer dimension is either defined by handwheel or housing.

Connection Dimensions

MULTI-TURN ACTUATOR DiM

MULTI-TURN ACTUATOR FOR MODULATING DUTY DiMR



Output drive form A Stem nut for rising spindle

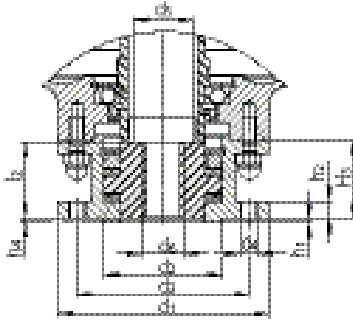

Actuator DiM	30	59	60 120	249	250 500	1000	2000	
Actuator DiMR	30	59	60 120		250 500	1000		
size	DIN EN ISO 5210	F07	F10	F10	F14	F14	F16	F25
	DIN 3210	-	G0	G0	G1/2	G1/2	G3	-
Dimensions [mm]								
d1	FORM A	90	125	125	175	175	210	350
d2 ₁₈	DIN EN ISO 5210	55	70	70	100	100	130	200
	DIN 3210	-	60	60	100	100	130	-
d3		70	102	102	140	140	165	254
d4	4 x	M8	M10	M10	M16	M16	M20	8 x M16
d5		26	30	40.5	40.5	52.5	65.5	85
d6 _{max}		24	28	40	40	52	65	85
h1 = h4		3	3	3	4	4	5	5
h2		12	16	16	22	23	35	24
H3		36	42	46	58	56	70	130
l2		34	41	40	54	54	68.5	130

Output drive form B1, B2, B Plug bush for rising spindle *

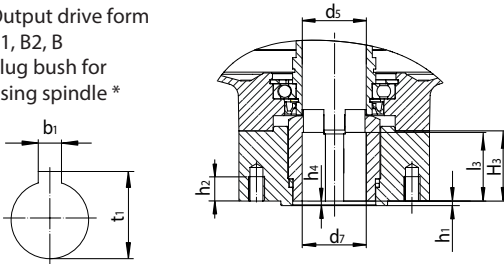

b1 ^{59P}	FORM B1, B	8	12	12	18	18	22	28
d5		26	30	40.5	40.5	52.5	65.5	85
d7 ^{19P}	B1, B	28	42	42	60	60	80	100
d7 _{max}	B2, B	28	42	42	60	65	80	100
H3		36	46	46	70	66	81	130
h1 = h4		3	3	3	4	4	5	5
t1	FORM B1, B	31.3	45.3	45.3	64.4	64.4	85.5	106.4

* missing dimensions see form A

Output drive form B3, B4, E *

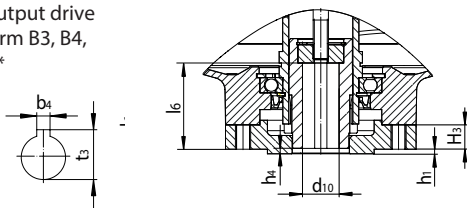

b4 ^{59P}	FORM B3, E	5	6	6	8	8	12	14
d10 ^{19P}	B3, E	16	20	20	30	30	40	50
d10 _{max}	B4, E	16	20	30	30	40	50	50
H3		18	17	16	22	23	28	30
h1 = h4		3	3	3	4	4	5	5
l _b		41	56	56	79	79	98	118
t3	FORM B3, E	18.3	22.8	22.8	33.3	33.3	43.3	53.8

* missing dimensions see form A

Output drive form C claw coupling *

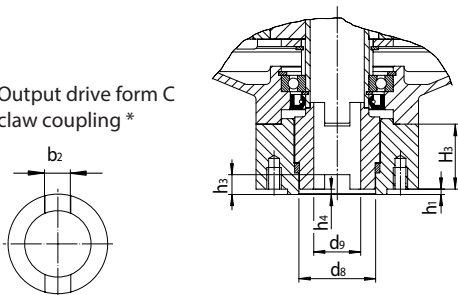

b2 ¹¹¹	FORM C	14	14	14	20	20	24	30
d5		42	54	54	80	85	110	139.9
d5		26	28	28	38	38	47	85
H3		36	46	46	70	66	81	130
h1 = h4		3	3	3	4	4	5	5
h3		11	11	11	14	14	17	16

* missing dimensions see form A

Output drive form D shaft extension *

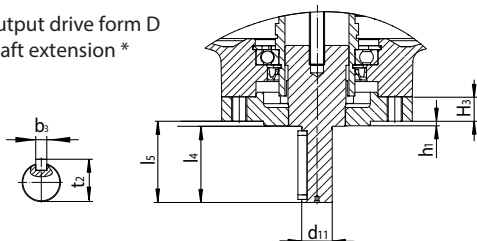

b3 ₁₀₉	FORM D	5	6	6	8	8	12	-
d11		16	20	20	30	30	40	-
H3		18	17	16	22	23	28	30
h1		3	3	3	4	4	5	5
l1		40	50	50	70	70	90	-
l2		45	55	55	76	76	96	-
t2		18	22.5	22.5	33	33	43	-

* missing dimensions see form A

Motor data

MULTI-TURN ACTUATOR DIM



Actuator Model		Motor (400 V / 3ph / 50 Hz, 480 V / 3ph / 60 Hz)											
		Output speed ¹⁾ [rpm]	Max. torque [Nm]	Motor type	Nominal Power ²⁾ P _N [kW]	Speed [rpm]	Nominal Current ³⁾ I _N [A]	load data		Starting Current I _N [A]	cos phi	DREHMO power class for switchgear	
								50 % Current ⁴⁾ I _{50%} [A]	100 % Current ⁵⁾ I _{100%} [A]			Contactor	Thyristor
DIM 30	S2-15 min	5	30	TM4.0105	0.12	1.360	0.53	0.4	0.4	1.5	0.66	A1	C1
		10		TM4.0105	0.12	1.360	0.53	0.4	0.4	1.5	0.66	A1	C1
		16		TM4.0105	0.12	1.360	0.53	0.4	0.5	1.5	0.66	A1	C1
		25		TM4.0105	0.12	1.360	0.53	0.5	0.7	1.5	0.66	A1	C1
		32		TM4.01013	0.34	2.840	1.10	1.1	1.1	4.8	0.62	A1	C1
		40		TM4.0106	0.25	1.360	1.10	1.0	1.1	2.7	0.65	A1	C1
	S2-10 min	50	TM4.01013	0.34	2.840	1.10	1.0	1.2	4.8	0.62	A1	C1	
		80	TM4.01013	0.34	2.840	1.10	1.4	1.8	4.8	0.62	A1	C1	
		120	TM4.01013	0.34	2.840	1.10	1.4	2.0	4.8	0.62	A1	C1	
		160	TM4.01014	0.75	2.800	2.00	2.0	2.5	10.0	0.70	A1	C1	
DIM 59	S2-15 min	5	60	TM4.0105	0.12	1.360	0.53	0.4	0.5	1.5	0.66	A1	C1
		10		TM4.0105	0.12	1.360	0.53	0.4	0.6	1.5	0.66	A1	C1
		16		TM4.0106	0.25	1.360	1.10	0.9	1.0	2.7	0.65	A1	C1
		25		TM4.0106	0.25	1.390	1.10	0.9	1.2	2.7	0.65	A1	C1
		32		TM4.01013	0.34	2.840	1.10	1.1	1.4	4.8	0.62	A1	C1
		40		TM4.0107	0.40	1.390	1.50	1.4	1.8	5.1	0.63	A1	C1
	S2-10 min	50	TM4.01014	0.75	2.800	2.00	1.8	2.2	10.0	0.70	A1	C1	
		80	TM4.01014	0.75	2.800	2.00	2.1	2.9	10.0	0.70	A1	C1	
		120	TM4.01014	0.75	2.800	2.00	2.1	3.2	10.0	0.70	A1	C1	
		160	TM4.01014	0.75	2.800	2.00	2.5	4.1	10.0	0.70	A1	C1	
DIM 60 S2-15 min	5	60	TM1.01005	0.12	1.360	0.57	0.6	0.7	1.5	0.62	A1	C1	
	10		TM1.01000	0.21	2.670	0.65	0.7	0.9	2.3	0.76	A1	C1	
	16		TM1.01001	0.42	2.700	1.15	1.0	1.3	4.6	0.81	A1	C1	
	25		TM1.01006	0.18	1.320	0.76	0.8	1.2	2.0	0.64	A1	C1	
	32		TM1.01001	0.42	2.700	1.15	1.0	1.3	4.6	0.81	A1	C1	
	40		TM1.01007	0.34	1.310	1.30	1.2	1.8	3.5	0.63	A1	C1	
	50		TM1.01001	0.42	2.700	1.15	1.4	1.9	4.6	0.81	A1	C1	
	80		TM1.01002	0.90	2.670	2.30	2.0	2.7	9.0	0.80	A1	C1	
	120		TM1.01002	0.90	2.670	2.30	2.7	4.2	9.0	0.80	A1	C1	
	160		TM1.01002	0.90	2.670	2.30	2.8	4.6	9.0	0.80	A1	C1	
DIM 120 S2-15 min	5	120	TM1.01007	0.34	1.310	1.30	1.0	1.2	3.5	0.63	A1	C1	
	10		TM1.01001	0.42	2.700	1.15	1.0	1.4	4.6	0.81	A1	C1	
	16		TM1.01002	0.90	2.670	2.30	1.7	2.1	9.0	0.80	A1	C1	
	25		TM1.01008	0.56	1.325	1.70	1.5	2.1	5.7	0.72	A1	C1	
	32		TM1.01002	0.90	2.670	2.30	1.8	2.3	9.0	0.80	A1	C1	
	40		TM1.01009	0.75	1.345	2.50	2.3	3.1	8.6	0.62	A1	C1	
	50		TM1.01002	0.90	2.670	2.30	2.2	3.4	9.0	0.80	A1	C1	
	80		TM1.01003	1.50	2.710	3.10	2.9	4.4	14.6	0.89	A1	C1	
	120		TM1.01004P	1.60	2.820	3.70	4.4	6.6	20.5	0.80	A1	C1	
	160		TM1.01004P	1.60	2.820	3.70	5.0	8.0	20.5	0.80	A1	C1	

Motor data

MULTI-TURN ACTUATOR DiM



Actuator Model		Motor (400 V / 3ph / 50 Hz, 480 V / 3ph / 60 Hz)											
		Output speed ¹⁾ [rpm]	Max. torque [Nm]	Motor type	Nominal Power ²⁾ P _N [kW]	Speed [rpm]	Nominal Current ³⁾ I _N [A]	load data		Starting Current I _N [A]	cos phi	DREHMO power class for switchgear	
								50 % Current ⁴⁾ I _{50%} [A]	100 % Current ⁵⁾ I _{100%} [A]			Contactor	Thyristor
DiM 249	S2-15 min	5	250	TM1.01007	0.34	1.310	1.30	1.1	1.8	3.5	0.63	A1	C1
		10		TM1.01008	0.56	1.325	1.70	1.4	1.9	5.7	0.72	A1	C1
		16		TM1.01008	0.56	1.325	1.70	1.7	2.5	5.7	0.72	A1	C1
		25		TM1.01009	0.75	1.345	2.50	2.5	4.1	8.6	0.62	A1	C1
		32		TM1.01003	1.50	2.710	3.10	2.4	4.0	14.6	0.89	A1	C1
		40		TM1.01010	0.80	1.390	3.60	3.6	6.0	11.2	0.50	A1	C1
	50	TM1.01003	1.50	2.710	3.10	3.5	6.6	14.6	0.89	A1	C1		
	S2-10 min	80	TM1.01004	1.60	2.820	3.70	5.3	9.6	20.5	0.80	A1	C1	
	120	200	TM1.01004P	1.60	2.820	3.70	⁶⁾	⁶⁾	20.5	0.80	A1	C1	
DiM 250	S2-15 min	5	250	TM1.01008	0.56	1.325	1.70	1.2	1.6	5.7	0.72	A1	C1
		10		TM1.01002	0.90	2.670	2.30	1.6	2.5	9.0	0.80	A1	C1
		16		TM1.01003	1.50	2.710	3.10	1.8	3.0	14.6	0.89	A1	C1
		25		TM1.01009	0.75	1.345	2.50	2.2	3.5	8.6	0.62	A1	C1
	S2-10 min	32		TM1.01003	1.50	2.710	3.10	2.2	4.3	14.6	0.89	A1	C1
	S2-15 min	40		TM2.01079	2.00	1.440	4.80	4.0	6.3	25.0	0.77	A2	C1
	S2-10 min	50		TM1.01003	1.50	2.710	3.10	2.7	6.1	14.6	0.89	A1	C1
		80		TM1.01004	1.60	2.820	3.70	4.4	10.1	20.5	0.80	A1	C1
		120		TM2.01075	4.00	2.900	9.00	7.8	17.6	57.0	0.80	A2	C2
		160		TM2.01076	6.00	2.870	13.90	9.9	19.9	76.0	0.78	A2	C2
DiM 500 S2-15 min	5	500	TM1.01009	0.75	1.345	2.50	2.1	2.7	8.6	0.62	A1	C1	
	10		TM1.01003	1.50	2.710	3.10	2.0	3.9	14.6	0.89	A1	C1	
	16		TM1.01004	1.60	2.820	3.70	3.2	5.8	20.5	0.80	A1	C1	
	25		TM2.01079	2.00	1.440	4.80	4.4	8.3	25.0	0.77	A2	C1	
	32		TM2.01075	4.00	2.900	9.00	5.0	9.6	57.0	0.80	A2	C2	
	40		TM2.01081	4.50	1.435	11.10	7.4	11.7	57.0	0.77	A2	C2	
	50		TM2.01075	4.00	2.900	9.00	6.2	14.5	57.0	0.80	A2	C2	
	80		TM2.01076	6.00	2.870	13.90	10.6	22.7	76.0	0.78	A2	C2	
	120		TM2.01078	8.50	2.875	18.70	14.4	31.6	112.0	0.82	A2	-	
	160		TM2.01078	8.50	2.875	18.70	16.3	37.7	112.0	0.82	A2	-	
	200		TB2.01076	6.00	2.870	13.90	⁶⁾	⁶⁾	76.0	0.78	A2	-	
	DiM 1000 S2-15 min		5	1000	TM1.01010	0.80	1.390	3.60	⁶⁾	⁶⁾	11.2	0.50	A1
10		TM1.01004	1.60		2.820	3.70	3.6	7.2	20.5	0.80	A1	C1	
16		TM2.01075	4.00		2.900	9.00	6.5	14.3	57.0	0.80	A2	C2	
25		TM2.01081	4.50		1.435	11.10	8.6	16.9	57.0	0.77	A2	C2	
32		TM2.01075	4.00		2.900	9.00	8.1	21.8	57.0	0.80	A2	C2	
40		TM2.01082	6.00		1.420	15.10	12.4	24.9	64.0	0.73	A2	C2	
50		TM2.01076	6.00		2.870	13.90	11.8	30.2	76.0	0.78	A2	C2	
80		TM2.01078	8.50		2.875	18.70	18.4	46.1	112.0	0.82	A2	-	
120		TB2.01082	6.00		1.420	15.10	13.3	27.3	64.0	0.73	A2	C2	
160		TB2.01078	8.50		2.875	18.70	17.7	40.9	112.0	0.82	A2	-	
200		TB2.01078	8.50		2.875	18.70	22.0	36.0	112.0	0.82	A2	-	
DiM 2000 S2-15 min		20	2000		RUF100L/40K	2.50	1.460	6.50	⁶⁾	⁶⁾	35.0	0.77	A2
	40	RUF112/4K		5.00	1.420	11.50	⁶⁾	⁶⁾	52.0	0.81	A2	C2	
	80	RUF112M/20KS		7.50	2.900	16.50	⁶⁾	⁶⁾	75.0	0.85	A2	-	
	120	RUF132M/20KS		14.00	2.900	26.50	⁶⁾	⁶⁾	170.0	0.87	A3	-	
	160	RUF132M/20KS		14.00	2.900	26.50	⁶⁾	⁶⁾	170.0	0.87	A3	-	
	200	RUF160L/2K		22.00	2.900	41.00	⁶⁾	⁶⁾	312.0	0.90	A4	-	

¹⁾ Output speed: increased by factor 1.2 at 60 Hz

²⁾ Nominal power P_N; Mechanical power at motor shaft (data on nameplate); increased by factor 1.2 at 60 Hz

³⁾ Nominal current I_N; Rated current of the motor (data on nameplate)

⁴⁾ 50 % current I_{50%}; Current at 50 % of maximum adjustable torque

⁵⁾ 100 % current I_{100%}; Current at 100 % of maximum adjustable torque

⁶⁾ on request

Motor data

MULTI-TURN ACTUATOR FOR MODULATING DUTY DiMR



Actuator Model	Motor (400 V / 3ph / 50 Hz, 480 V / 3ph / 60 Hz)											
	Output speed ¹⁾ [rpm]	Max. torque [Nm]	Motor type	Nominal Power ²⁾ P _N [kW]	Speed [rpm]	Nominal Current ³⁾ I _N [A]	load data		Starting Current I _N [A]	cos phi	DREHMO power class for switchgear	
							50 % Current ⁴⁾ I _{50%} [A]	100 % Current ⁵⁾ I _{100%} [A]			Contactor	Thyristor
DiM R 30	5	30	TM4.0105	0.12	1.360	0.53	0.4	0.4	1.5	0.66	A1	C1
	10		TM4.0105	0.12	1.360	0.53	0.4	0.4	1.5	0.66	A1	C1
	16		TM4.0105	0.12	1.360	0.53	0.4	0.5	1.5	0.66	A1	C1
	25		TM4.0105	0.12	1.360	0.53	0.5	0.7	1.5	0.66	A1	C1
	32		TM4.01013	0.34	2.840	1.10	1.1	1.1	4.8	0.62	A1	C1
	40		TM4.0106	0.25	1.360	1.10	1.0	1.1	2.7	0.65	A1	C1
DiM R 59	5	60	TM4.0105	0.12	1.360	0.53	0.4	0.5	1.5	0.66	A1	C1
	10		TM4.0105	0.12	1.360	0.53	0.4	0.6	1.5	0.66	A1	C1
	16		TM4.0106	0.25	1.360	1.10	0.9	1.0	2.7	0.65	A1	C1
	25		TM4.0106	0.25	1.390	1.10	0.9	1.2	2.7	0.65	A1	C1
	32		TM4.01013	0.34	2.840	1.10	1.1	1.1	4.8	0.62	A1	C1
	40		TM4.0107	0.40	1.390	1.50	1.4	1.8	5.1	0.63	A1	C1
DiM R 60	5	60	TM1.01005	0.12	1.360	0.57	0.6	0.7	1.5	0.62	A1	C1
	10		TM1.01000	0.21	2.670	0.65	0.7	0.9	2.3	0.76	A1	C1
	16		TM1.01001	0.42	2.700	1.15	1.0	1.3	4.6	0.81	A1	C1
	25		TM1.01006	0.18	1.320	0.76	0.8	1.2	2.0	0.64	A1	C1
	32		TM1.01001	0.42	2.700	1.15	1.0	1.3	4.6	0.81	A1	C1
	40		TM1.01007	0.34	1.310	1.30	1.2	1.8	3.5	0.63	A1	C1
DiM R 120	5	120	TM1.01007	0.34	1.310	1.30	1.0	1.2	3.5	0.63	A1	C1
	10		TM1.01001	0.42	2.700	1.15	1.0	1.4	4.6	0.81	A1	C1
	16		TM1.01002	0.90	2.670	2.30	1.7	2.1	9.0	0.80	A1	C1
	25		TM1.01008	0.56	1.325	1.70	1.5	2.1	5.7	0.72	A1	C1
	32		TM1.01002	0.90	2.670	2.30	1.8	2.3	9.0	0.80	A1	C1
	40		TM1.01009	0.75	1.345	2.50	2.3	3.1	8.6	0.62	A1	C1
DiM R 250	5	250	TM1.01008	0.56	1.325	1.70	1.2	1.6	5.7	0.72	A1	C1
	10		TM1.01002	0.90	2.670	2.30	1.6	2.5	9.0	0.80	A1	C1
	16		TM1.01003	1.50	2.710	3.10	1.8	3.0	14.6	0.89	A1	C1
	25		TM1.01009	0.75	1.345	2.50	2.2	3.5	8.6	0.62	A1	C1
	32		TM1.01003	1.50	2.710	3.10	2.2	4.3	14.6	0.89	A1	C1
	40		TMR2.01079	2.00	1.440	4.80	4.0	6.3	25.0	0.77	A2	C1
DiM R 500	5	500	TM1.01009	0.75	1.345	2.50	2.1	2.7	8.6	0.62	A1	C1
	10		TM1.01003	1.50	2.710	3.10	2.0	3.9	14.6	0.89	A1	C1
	16		TM1.01004	1.60	2.820	3.70	3.2	5.8	20.5	0.80	A1	C1
	25		TMR2.01079	2.00	1.440	4.80	4.4	8.3	25.0	0.77	A2	C1
	32		TMR2.01075	4.00	2.900	9.00	5.0	9.6	57.0	0.80	A2	C2
	40		TMR2.01081	4.50	1.435	11.10	7.4	11.7	57.0	0.77	A2	C2
DiM R 1000	5	1000	TMR2.01079	2.00	1.440	4.80	3.1	7.2	25.0	0.77	A1	C1
	10		TMR2.01080	3.00	1.420	8.10	6.0	7.9	40.0	0.71	A1	C1
	16		TMR2.01082	6.00	1.420	15.10	7.6	13.7	100.0	0.73	A2	C2
	25		TMR2.01082	6.00	1.420	15.10	10.4	15.8	100.0	0.73	A2	C2

¹⁾ Output speed: increased by factor 1.2 at 60 Hz

²⁾ Nominal power P_N; Mechanical power at motor shaft (data on nameplate); increased by factor 1.2 at 60 Hz

³⁾ Nominal current I_N; Rated current of the motor (data on nameplate)

⁴⁾ 50 % current I_{50%}; Current at 50 % of maximum adjustable torque

⁵⁾ 100 % current I_{100%}; Current at 100 % of maximum adjustable torque

Technical data

PART-TURN ACTUATOR FOR DPiM

PART-TURN ACTUATOR FOR MODULATING DUTY DPiMR



Actuator Model	Operating Time for 90° χ [sec] 50 Hz	Operating Time for 90° χ [sec] 60 Hz	Torque adjustment range [Nm]	Torque adjustment range modulating actuator [Nm]	Max. modulating torque [Nm]	Connection Flange According to DIN EN ISO 5211	max. bore diameter of output drive V [mm]	max width of square bore output drive L/D [mm]	Type of Duty S 2-... [min]	Type of Duty S 4-... [%ED]
DPiM (R) 75	8, 16, 24, 34	7, 13, 20, 28	25-75	37.5-75	37,5	F05 F07 F10*	28	22	15	25
DPiM (R) 150			50-150	75-150	75	F05 F07 F10*	28	22	15	25
DPiM (R) 299			125-300	150-300	150	F07 F10*	28	22	15	
DPiM (R) 300			125-300	150-300	150	F10 F12*	38	30	15	25
DPiM (R) 450			250-450	225-450	225	F10 F12*	38	30	15	25
DPiM (R) 600	8,16,32,48,67	7,13,26,40,56	200-600	300-600	300	F12 F14*	50	36	15	25
DPiM (R) 900			500-900	450-900	450	F12 F14*	50	36	15	25
DPiM (R) 1200	7**,18,36, 55,75	6,15,30,46,63	500-1200	600-1200	600	F14 F16*	60	46	15	25
DPiM (R) 1800			1000-1800	900-1800	900	F14 F16*	60	46	15	25

* On special request.

** not available as modulating actuator

The max. torques given by DIN EN ISO 5211 to each flange size must not be exceeded.

For higher torques please request more information.

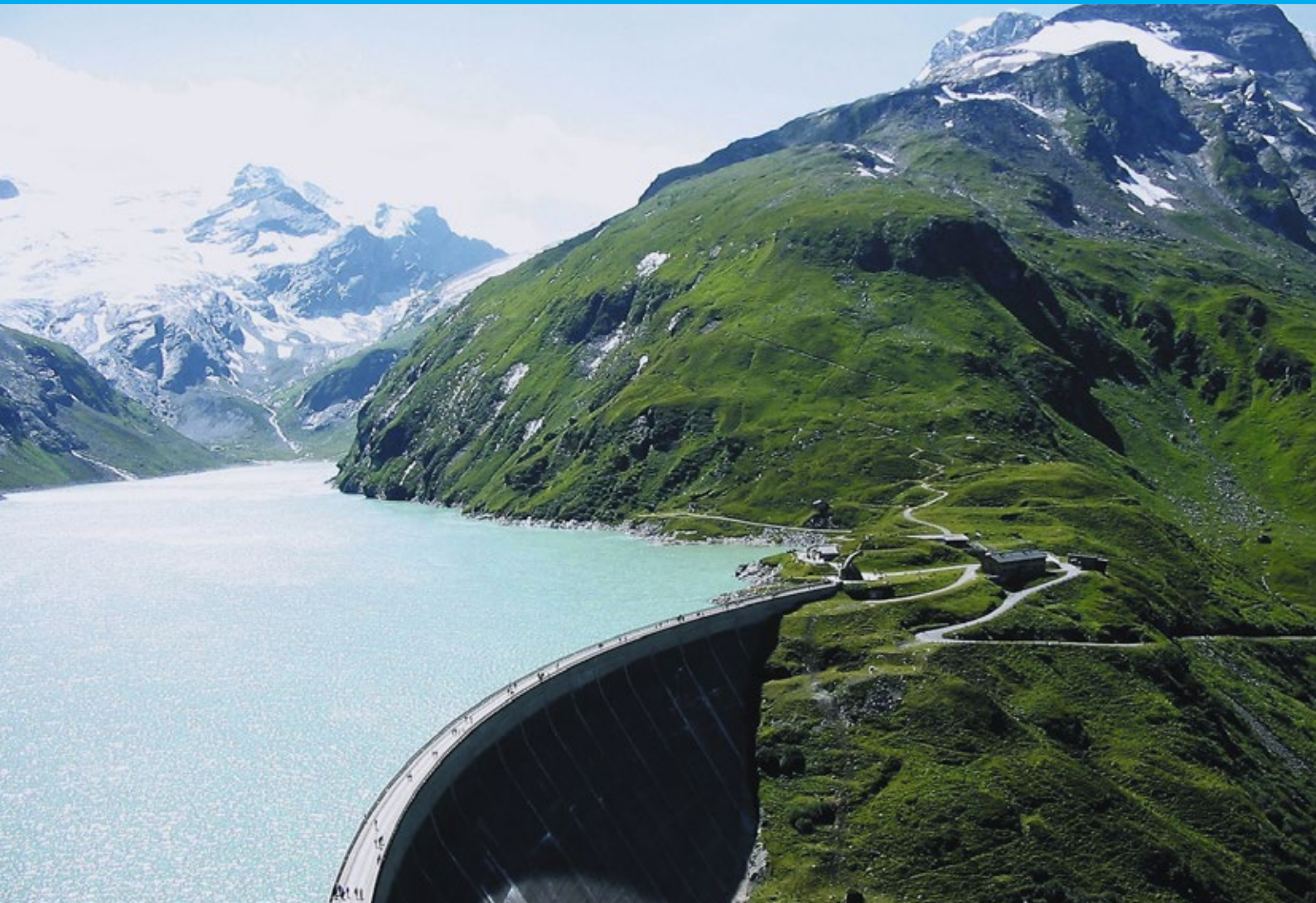

Actuator dimensions

PART-TURN ACTUATOR FOR DPiM

PART-TURN ACTUATOR FOR MODULATING DUTY DPiMR



Actuator DPiM, DPiMR Models	75/150/299	300/450	600/900	1200/1800
Weight [kg]	32	34	40	45
Dimensions [mm]				
L max	561			
T4 max	287			
H max.	427	444	463	528
D1	Ø160			
D2 max.	Ø127			
H1a	394	411	430	495
H1b	427	444	463	528
H2	352	369	388	453
H4	163	180	199	264
HR	45			
L2	209			
L3	499			
L5	63			
T1	102			
T2	179			
T3	178			
T4a	287			
IM-Unit ²⁾	408 x 153 x 163 (L x T x H)			

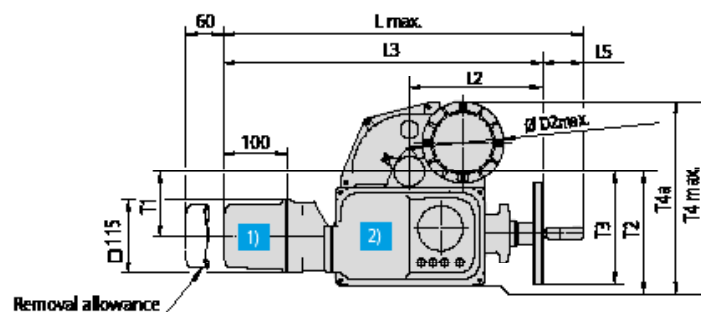
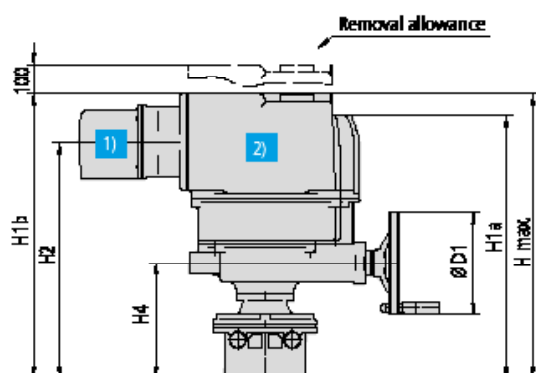

¹⁾ Cover for electrical connection S refer to page 12. Options available.

²⁾ Electronic unit (IM-unit) coversize including cover for electrical connection

Connection dimensions

PART-TURN ACTUATOR FOR DPiM

PART-TURN ACTUATOR FOR MODULATING DUTY DPiMR



Actuator DPiM(R)	75/150/299			300/450		600/900		1200/1800	
Size DIN EN ISO 5211	F05	F07	F10	F10	F12	F12	F14	F14	F16
Dimensions [mm]									
d1	90	90	125	125	150	150	175	175	210
d2 ¹⁸	35	55	70	70	85	85	100	100	130
d3	50	70	102	102	125	125	140	140	165
d4	M6	M8	M10	M10	M12	M12	M16	M16	M20
d5	16			16		22		22	
d6	11			11		14		18	
h*	2.5			2.5		2.5		2.5	
h1	12			12		16		16	
h2	110			130		170		180	
thread depth d4	12	15	16	18	19	22	25	29	32
Lmax	40		66	50	82	61	102	75	127
l6	10			10		16		19	
l7	40			40		45		45	
l8	20			20		26		26	
l9	80			80		90		100	
l10	40			40		45		50	
l11	25			25		30		35	
l12	120			120		135		150	
l13	80			80		110		110	
l14	150			150		190		225	
r1	150			150		150		150	
r2	200			200		200		200	
r3	-			-		250		250	
r4	218			218		273		273	

Length unit: mm

* Allowance for spigot is not available as standard. The spigot ring is a separate component, available as option.

DIRECT MOUNTING

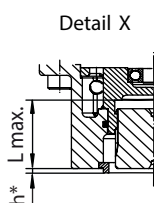
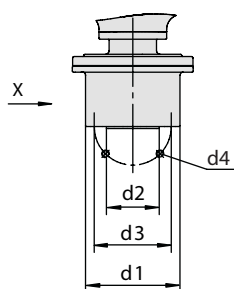

FOOT AND LEVER

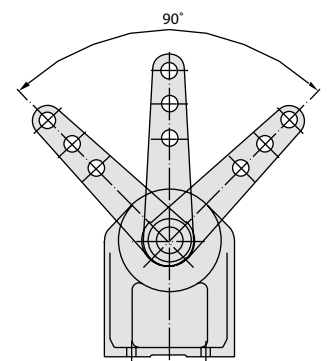
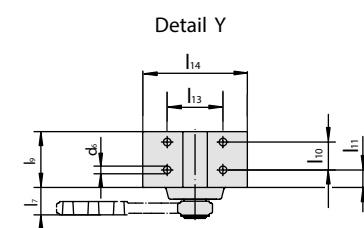
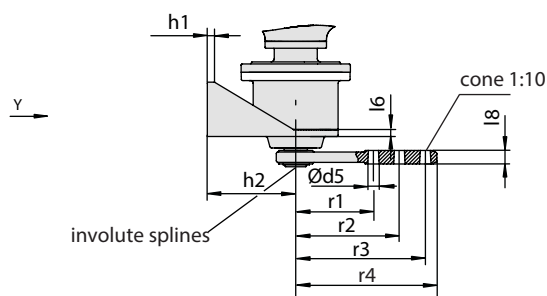

Output drive forms

Bore according to ISO 5211
With keyway (form V)
according to DIN 6885-1

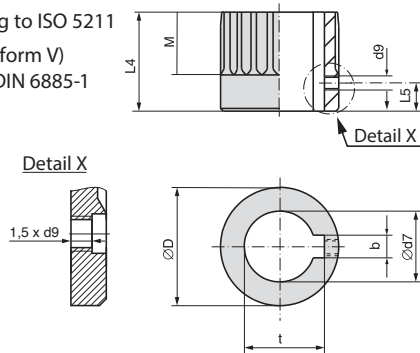

Dimensions	DPiM 75/150		DPiM 299		DPiM 300/450		DPiM 600/900		DPiM 1200/1800	
	F05	F07	F07	F10	F10	F12	F12	F14	F14	F16
Ø D	41.75		41.75		51.75		67.6		81.6	
b JS9 ¹⁾	6		6		8		10		14	
Ø d7 H8 ²⁾	18		22		28		36		48	
Ø d7 max.	28		28		38		50		60	
d9 ³⁾	M5		M5		M6		M6		M6	
L4	35		35		45	75	55	95	65	115
L5 ³⁾	8		8		10		10		10	
M	20		20		30		40		47	40
t ¹⁾	20.8		24.8		31.3		39.3		51.8	

Square bore (form L/D)
according to ISO 5211

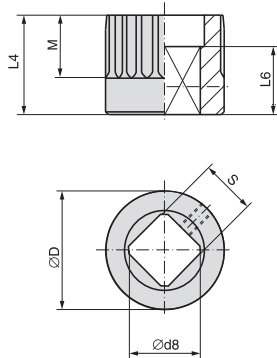

Dimensions	DPiM 75/150		DPiM 299		DPiM 300/450		DPiM 600/900		DPiM 1200/1800	
	F05	F07	F07	F10	F10	F12	F12	F14	F14	F16
Ø D	41.75		41.75		51.75		67.6		81.6	
Ø d8 min. ²⁾	18.1		22.2		28.2		36.2		48.2	
Ø d8 max.	28.2		28.2		40.2 ⁴⁾		48.2		60.2	
L4	35		35	60	45	75	55	95	65	115
L6 min.	30		30		30		30		40	
M	20		20		30		40		47	40
s H11 ²⁾	14		17		22		27		36	
s H11 max.	22		22		30 ⁴⁾		36		46	

Bore with two-flats (form H)
according to ISO 5211

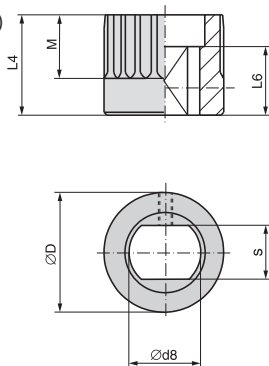

Dimensions	DPiM 75/150		DPiM 299		DPiM 300/450		DPiM 600/900		DPiM 1200/1800	
	F05	F07	F07	F10	F10	F12	F12	F14	F14	F16
Ø D	41.75		41.75		51.75		67.6		81.6	
Ø d8 min. ²⁾	18.1		22.2		28.2		36.2		48.2	
Ø d8 max.	28.2		28.2		36.2		48.2 (48 ⁵⁾)		60.2	
L4	35		35	60	45	75	55	95	65	115
L6 min.	25		25		25		30		40	
M	20		20		30		40		47	40
s H11 ²⁾	14		17		22		27		36	
s H11 max.	22		22		27		36 (41 ⁵⁾)		46	

Mounting position of coupling

X max.	3	4	5	8
Y max.	2	5	10	10

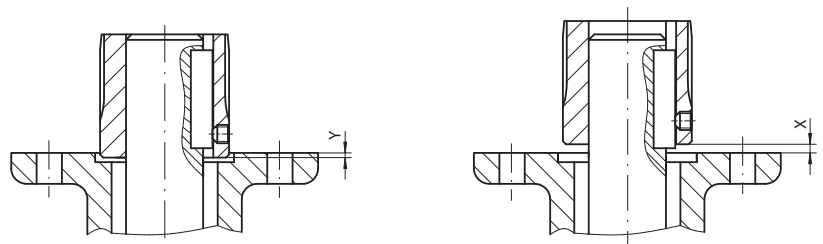

- 1) Dimensions depend on Ø d7, refer to DIN 6885-1
- 2) Recommended size according to ISO 5211
- 3) Thread with grub screw
- 4) According to DIN 79
- 5) According to DIN 475

Motor data

PART-TURN ACTUATOR FOR DPiM

PART-TURN ACTUATOR FOR MODULATING DUTY DPiMR



Actuator Model	Operating Time for 90° α [sec] 50 Hz	Operating Time for 90° α [sec] 60 Hz	Rated Power 50 Hz ¹⁾ [kW]	Rated Power 60 Hz ¹⁾ [kW]	Rated Current ²⁾ [A]	Starting Current [A]	cos phi	Eta [%]
DPiM (R) 75	8	7	0.04	0.05	0.18	0.51	0.81	39
	16	13	0.04	0.05	0.18	0.51	0.81	39
	24	20	0.10	0.12	0.49	1.24	0.57	56
	34	28	0.08	0.10	0.61	0.98	0.55	43
DPiM (R) 150	8	7	0.12	0.14	0.53	1.50	0.66	50
	16	13	0.12	0.14	0.53	1.50	0.66	50
	24	20	0.10	0.12	0.49	1.24	0.57	56
	34	28	0.08	0.10	0.61	0.98	0.55	43
DPiM (R) 299	8	7	0.12	0.14	0.53	1.50	0.66	50
	16	13	0.12	0.14	0.53	1.50	0.66	50
	24	20	0.10	0.12	0.49	1.24	0.57	56
	34	28	0.08	0.10	0.61	0.98	0.55	43
DPiM (R) 300	8	7	0.12	0.14	0.53	1.50	0.66	50
	16	13	0.12	0.14	0.53	1.50	0.66	50
	24	20	0.10	0.12	0.49	1.24	0.57	56
	34	28	0.08	0.10	0.61	0.98	0.55	43
DPiM (R) 450	8	7	0.25	0.30	1.10	2.70	0.65	50
	16	13	0.12	0.14	0.53	1.50	0.66	50
	24	20	0.10	0.12	0.49	1.24	0.57	56
	34	28	0.08	0.10	0.61	0.98	0.55	43
DPiM (R) 600	8	7	0.34	0.41	1.10	4.80	0.62	59
	16	13	0.12	0.14	0.53	1.50	0.66	50
	32	26	0.12	0.14	0.53	1.50	0.66	50
	48	40	0.10	0.12	0.49	1.24	0.57	56
	67	56	0.08	0.10	0.61	0.98	0.55	43
DPiM (R) 900	8	7	0.34	0.41	1.10	4.80	0.62	59
	16	13	0.25	0.3	1.10	2.70	0.65	50
	32	26	0.12	0.14	0.53	1.50	0.66	50
	48	40	0.10	0.12	0.49	1.24	0.57	56
	67	56	0.08	0.10	0.61	0.98	0.55	43
DPiM (R) 1200	7 ³⁾	6 ³⁾	0.34	0.41	1.10	4.80	0.62	59
	18	15	0.34	0.41	1.10	4.80	0.62	59
	36	30	0.12	0.14	0.53	1.50	0.66	50
	55	46	0.10	0.12	0.49	1.24	0.57	56
	75	63	0.12	0.14	0.53	1.50	0.66	50
DPiM (R) 1800	7 ³⁾	6 ³⁾	0.75	0.90	2.00	10.00	0.70	59
	18	15	0.34	0.41	1.10	4.80	0.62	59
	36	30	0.12	0.14	0.53	1.50	0.66	50
	55	46	0.10	0.12	0.49	1.24	0.57	56
	75	63	0.12	0.14	0.53	1.50	0.66	50

All shown figures are based on 400 V/3 ph/50 Hz and 480 V/3 ph/60 Hz.

¹⁾ Nominal power P_N ; Mechanical power at motor shaft (data on nameplate)

²⁾ Nominal current I_N ; Rated current of the motor (data on nameplate)

³⁾ Operating time for 90°; no modulating duty available

Wiring diagrams

WIRING DIAGRAM VERSION IMC 003 FOR INCHING DUTY



380V C+D	440/460V C+E
400V B+D	480V B+E
415V A+D	500V A+E

Befehls- und Meldeausgänge frei programmierbar (Werkseinstellung siehe Konfigurationsliste)
command inputs and indication outputs are free programmable (factory setting acc. to configuration list)

- In1: Stop
- In2: Close
- In3: Open
- In4: Automatic (bei IMC003 „free“)

- Out1: Position close(d)
- Out2: Position open
- Out3: Closing torque
- Out4: Opening torque
- Out5: Remote control
- Out6: Local control
- Out7: Operational OK (Available)

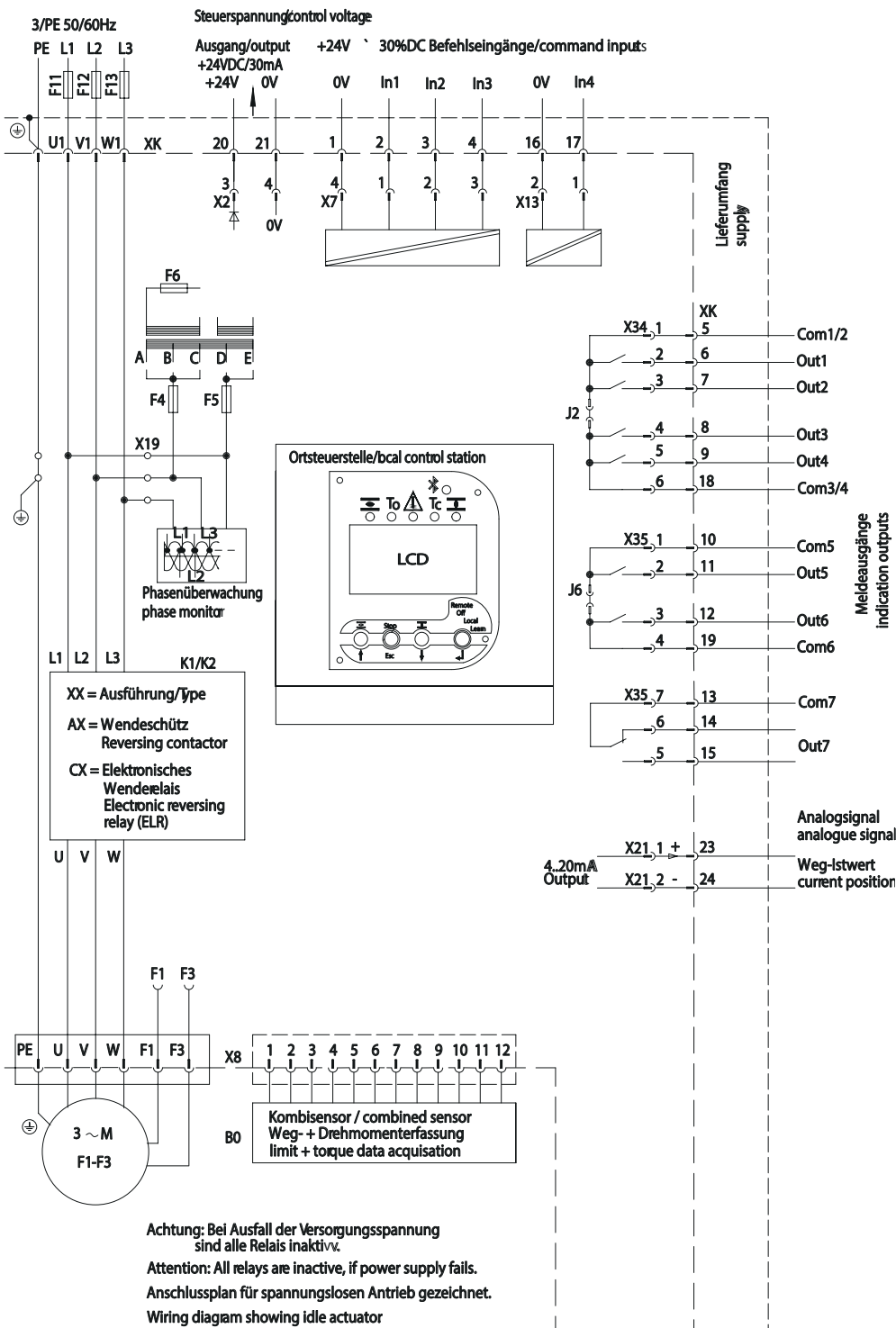

Specification

TYPES: DiM30 ... DiM2000, DPiM75 ... DPiM1800

BASIC VERSION

- > Valve attachment: According to EN ISO 5210 or DIN 3210, EN ISO 5211
- > Mains voltage: 380 – 400 – 415 – 440 – 460 – 500 V at 50 Hz/ 60 Hz
- > Motor: DREHMO 3-phase AC squirrel cage motor, insulation class F, 3 thermostiches
- > Type of duty : Short-time duty S2 - max. 15 min
- > Actuator self locking
- > Control unit: Combined sensor for position and torque sensing
- > Controls
 - Switchgear: Reversing contactors (mechanically and electrically locked)
 - I/O interface: Control signals (programmable, potential-free) 24 V DC, 3+1 potential-free and freely programmable command inputs
Status indication (programmable, potential-free): 2+2+1+1 NO contacts and 1 change-over contact
analog position indication 4 - 20mA
 - > Local Controls
 - Operation: 4 multi-function push buttons, Modes: LOCAL - OFF - REMOTE - LEARN
Menu Navigation: UP, ESCAPE, DOWN, ENTER, (lockable)
Operation: OPEN - STOP - CLOSE
 - Indication lights: 6 indication lights (colour coding programmable for 5): End position CLOSED, torque fault CLOSE, fault, torque fault OPEN, end position OPEN, Bluetooth (blue)
- > Output drive: for valve connection acc. to DIN EN ISO 5210 respectively DIN EN ISO 5211
- > Interface: Bluetooth
- > Display: Graphical LC Display 200 x 100 Pixel
- > Wiring diagram: iMC003-XX-AA-XA0/1
- > Enclosure protection: IP68 according to IEC 605293
- > Ambient temperature: -25 °C to +70 °C
- > Corrosion protection: K3
- > Colour: RAL 5015/sky blue
- > Handwheel: Handwheel for manual operation / without switch-over mechanism
- > Electrical connection: plug/socket connector with screw-type connection

OPTIONS

- > mains voltage 1phase AC or DC
- > various mains voltage options 110 V – 690 V, 3phases AC, 50/60 Hz
- > Integrated fieldbus interface Profibus DP, DP-V1, DP-V2, Modbus RTU, Modbus TCP/IP, Foundation Fieldbus, Wireless HART
- > Solid state relays for motors up to 4,5 kW
- > Fieldbus redundancy; fibre optics interface
- > Corrosion protection K4 (C4 according to EN ISO 12944-2) for aggressive atmospheres
- > Corrosion protection K5 (C5 according to EN ISO 12944-2) for extremely aggressive atmospheres
- > plug/socket connector with different threaded holes
- > Compact plug connector (with industrial power and control connectors)
- > detached control
- > various protection means
- > accumulator for control power supply
- > torque and limit switch unit in combination with detached control
- > enhanced temperature ranges in between -50°C to + 100°C



DREHMO

VALVE ACTUATORS



Maroc Sealing
FLUID CONTROL



92, Lot Mauritanie - Zone Industrielle Bernoussi
Casablanca MAROC 20590



www.marocsealing.com



marocsealing@marocsealing.com



(+212) 05 22 35 41 49/50



(+212) 05 22 35 41 52



(+212) 06 62 14 80 39